



January 2026

Dear Proposer –

Thank you for your interest in partnering with the Ohio Bureau of Motor Vehicles (“BMV”) to deliver services to residents throughout the state as an independently contracted Deputy Registrar (“DR”). The BMV relies upon its network of DR agencies to provide all in-person retail services to the millions of people who call Ohio home. As partners, the BMV will provide the direction, support, and oversight needed for each Deputy Registrar to succeed in their role of delivering quality products, with efficient service, in a clean environment, using knowledgeable and courteous staff.

While considering your interest in becoming, or continuing as, a DR in a particular community, each proposer should give serious thought to whether an existing location is truly the right fit for the area it serves. For Deputy-provided locations, an existing site may not be properly sized or adequately configured to meet the needs of the service area. At BMV site-controlled locations – typically those co-located with driver examination or county title offices – the BMV continuously monitors transaction load to ensure the facility can best meet capacity. With statewide requirement of the successful “Q-Flow” and “*Get In Line, Online*” queuing program, specific consideration of a seated waiting area is strongly encouraged. For both location types, the BMV welcomes proposals to change, update and/or outfit facilities for the future.

Throughout the contract term, each DR agency is regularly evaluated to ensure relevant products and services are delivered properly and professionally. Using time-tested common benchmarks of quality, service, and cleanliness, the BMV evaluation process is a significant factor in both assessing DR performance throughout the contract term and consideration of contract renewal. Periodic evaluations are necessary to encourage excellence and foster improvement – with the customer benefitting the most overall.

The Ohio BMV strives to continuously improve service and value to its customers. Success requires committed DR agency professionals who share that goal. The BMV is looking forward to contracting with motivated parties to serve Ohioans in 2026 and beyond.

Charles L. Norman, Registrar
1970 W. Broad Street
P.O. Box 16520
Columbus, Ohio 43216-6520 U.S.A.

Additional information regarding updates or changes to the 2026 Request for Proposal (RFP) process and the Deputy Registrar Contract Terms and Conditions are highlighted below:

Notable RFP and DR Contract Terms & Conditions Updates/Changes

- All proposals **MUST** be submitted electronically via email to DeputyRegistrarRFP@dps.ohio.gov.
- Hiring of employees under the age of 18 is permitted if they are serving in a capacity that does **NOT** require a background check and/or the signing of a computer compliance agreement.
- Submission of *Personnel, Security, and Facility Maintenance* plans will not be required. Proposers will be asked (Yes/No) to establish and maintain agency policies covering BMV required items. *Personnel, Security, and Facility Maintenance* policies will be regularly audited by BMV Field Operations staff as part of its ongoing evaluation of deputy registrar operations and performance.
- Deputy registrar shall accept responsibility for providing all necessary standard copy/print paper, as well as all standard toner cartridges for BMV-provided printers to properly operate. Detailed specifications for deputy registrar-provided paper and toner, along with minimum acceptable inventory levels, will be maintained in the Deputy Registrar Manual.
- Deputy registrar shall, within six (6) months of the contract award, update all agency signage to reflect the BMV logo (brand).
- Proposers may submit a proposal for a deputy provided location outside of BMV established boundaries. If proposing a deputy provided location outside of BMV established boundaries, however, the proposer must also submit a location **within** the BMV established boundaries. Proposed locations inside and outside of established boundaries are subject to BMV approval/disapproval.
- Proposers are encouraged to select locations already equipped with a 100MHz circuit when proposing new locations not currently operating as deputy registrar agencies. Doing so will greatly reduce the timeframe necessary for build-out/construction to ensure agency is suitable for BMV equipment operation.
- When proposing a deputy provided location, proposers are encouraged to factor in the physical footprint of knowledge testing kiosks, inventory storage, and queuing equipment in addition to the recommended square footage provided within the agency specifications.
- Proposers applying for contracts at existing license agency locations designated as deputy provided sites are **NOT** required to complete and submit all Section 5 forms if the site was approved under a previous RFP and if there have been no changes to the site since the last contract was approved and signed. Please see the Site Forms Packet for additional information.
- All deputy provided location proposals (which include incumbent deputy registrars) must complete Form 5.3 (Lease Option).
- Proposers should submit a professional resume as part of the *Personal Questionnaire* (Question 28 in Section 3.1). Nonprofit Corporations should provide a description of the fundraising, program, and charitable functions of the nonprofit corporation.

- Removal of minimum county population requirements for County Clerk of Courts and County Auditors to operate as deputy registrars.
- Removal of requirement to maintain a minimum of one deputy registrar agency in each county.
- Removal of requirement for deputy registrar to maintain a permanent residence within a one-hour commute of their agency.
- Addition to Agency Specifications of annual 8-year DL/ID transaction percentages.
- Updates notating the acceptance of CORSA General Liability Insurance, instead of Individual Surety Bond, for county entities (County Clerk of Court and County Auditor) serving in a deputy registrar capacity.



Request For Proposals (RFP)
For Deputy Registrar Appointees - 2026
QUICK GUIDE

RFP Schedule, January 2026 Page 2

Submission Instructions Page 3

Table of Contents Pages 4-7

The BMV has established a method to submit questions and view answers related to this RFP through an email account that can be directly accessed from the Ohio BMV Website through the following Internet address: [Ohio BMV](#).

To request copies of past proposals, contact the BMV by email at DeputyRegistrarRFP@dps.ohio.gov or by telephone at (614) 752-2090.

This RFP is available for download online from the Ohio BMV Internet site. To download the RFP, Forms, or to read answers to questions, visit the RFP website at the following Internet address: <http://www.bmv.ohio.gov> (listed as "Deputy Registrar Business Opportunity") or directly at: <http://bmv.ohio.gov/dr-rfp.aspx>.

NOTE: Keep a printed or electronic copy of this entire RFP document. If you are awarded a contract, the RFP defines the terms of your rights, authority, duties, and obligations.

RFP SCHEDULE, JUNE 2026

The Ohio Bureau of Motor Vehicles (BMV) has opted to reject any/all proposals submitted for location 25-E in Columbus (Franklin County). A separate RFP, solely for location 25-E, will open Monday, June 1, 2026. All RFP instructions and requirements still apply and shall be adhered to when submitting a proposal for location 25-E. Below you will find the applicable schedule as well as agency specifications for location 25-E. Any questions should be directed to the RFP email inquiry system.

Schedule

June 1, 2026

- Release of rebid RFP specifically for location 25-E; beginning date of solicitation of proposals.
- The RFP email inquiry system will resume operation.

June 12, 2026

- **(FRIDAY) NO LATER THAN 4:00 PM:** Proposals must be **received** by the BMV, **no later than 4:00 PM**. “Received” means **actually received via the RFP email address:** DeputyRegistrarRFP@dps.ohio.gov.
 - Note: Proposers will receive a confirmation email when their proposal is received.

June 16, 2026

- **(TUESDAY) AT 5:00 PM:** Preliminary scores will be announced and posted on the Ohio Bureau of Motor Vehicles internet site at: <https://www.bmv.ohio.gov/dr-rfp.aspx>.

June 17, 2026

- **(WEDNESDAY) NO LATER THAN 4:00 PM:** Written Response and Comments, if submitted, must be **received** by the BMV **no later than 4:00 PM**. “Received” means **actually received via the RFP email address:** DeputyRegistrarRFP@dps.ohio.gov.

June 18, 2026

- **(THURSDAY) AT 5:00 PM:** The tentative contract awards will be announced and posted on the Ohio Bureau of Motor Vehicles internet site at: <https://www.bmv.ohio.gov/dr-rfp.aspx>.

EMAIL DELIVERY INSTRUCTIONS

REMINDER: ALL DOCUMENTS MUST BE RECEIVED BY THE BMV ON OR BEFORE THE DEADLINES CONTAINED IN THE RFP SCHEDULE.

NOTICE: A CONFIRMATION EMAIL WILL BE SENT BY A BMV REPRESENTATIVE WITHIN 48 HOURS OF RECEIVING A SUBMITTED PROPOSAL

- **All proposals shall now be submitted by email to the following email address:**

DeputyRegistrarRFP@dps.ohio.gov

- Proposal submissions by any other mechanism (fax, in-person, mail, etc.) will no longer be accepted.
- Proposals should be saved and submitted via email in the following format:

Proposer Name, Location Number(s), Packet Type (Personal, Operational, or Site)

Example: John Smith, 67-C, Operational Forms Packet

- If submitting proposals for more than one location (not to exceed six locations):

Example: John Smith, 25-A, 25-B, 25-C, etc., Packet Type (Personal, Operational, or Site)

- When submitting proposals for multiple locations, only one (1) Personal Forms packet needs completed and submitted. The submitted Personal Forms packet will be used for all proposed locations.
- When submitting proposals for multiple locations, separate Operational Forms packets need submitted for EACH proposed location.
- Submissions must include any/all attachments and applicable documents necessary to satisfy RFP requirements.
- Emailed submissions are limited to a maximum attachment size of 20MB. Any submissions exceeding 20MB must be submitted via multiple emails.

TABLE OF CONTENTS

<u>Section 1</u>	Request for Proposals	<u>Page</u>
1.1	Purpose	1-1
1.2	Background	1-1
1.3	Authority	1-1
1.4	Services to be Performed.....	1-2
	Administrative Rules.....	1-2
	General Duties.....	1-2
	Nature of Contract.....	1-3
	Other Competitive Factors	1-3
1.5	Agency Specifications.....	1-3
	Geographical Area.....	1-3
	Type of Site	1-4
	BMV Controlled Sites.....	1-4
	Deputy Provided Sites.....	1-4
	Estimated Annual Transactions.....	1-4
	Agency Size and Staffing.....	1-4
	“Annual Transactions”	1-5
	“Agency Class Size”	1-5
	“Computer Terminals”	1-5
	“Recommended Weekly Staff Hours”.....	1-6
	“Minimum Parking Spaces”	1-6
	“Minimum Square Footage”	1-6
	Non-Exclusive Territories	1-6
	Changes to Number of Agencies.....	1-6
	Bond Requirements	1-7
	Other Information.....	1-7
1.6	Exclusions and Qualifications	1-7
	Exclusions	1-7
	Nonprofit Corporations May be Awarded a Contract	1-9
	Residency Requirements	1-9
1.7	No Political Considerations.....	1-9
	Political Contribution Limitations.....	1-9
	Explanation of Political Contribution Limitations	1-9
1.8	Requirements of Operation	1-10
	General	1-10
	Office Hours	1-10
	Computers and BMV Supplied Equipment.....	1-10
	Inventory	1-10
	Other Expenses Owed to BMV	1-11
	Deputy Registrar Responsibilities.....	1-11
	Insurance, Reimbursement, and Hold-Harmless.....	1-11
	Bonding.....	1-11

TABLE OF CONTENTS

<u>Section 1</u>	Request for Proposals	<u>Page</u>
1.8	Requirements of Operation (Cont'd.).....	1-12
	Banking Specifications.....	1-12
	Credit and Debit Cards.....	1-12
	Prohibition against Commingling.....	1-12
	Telephone Accessibility.....	1-12
	Emergencies.....	1-12
1.9	Employees.....	1-12
	General.....	1-12
	Bilingual Employees.....	1-13
	Personnel Policy.....	1-13
	Training.....	1-13
	Office Management.....	1-14
	Employee Standards.....	1-14
	Staffing Levels.....	1-14
	Employee Age Requirement.....	1-14
1.10	Fees to be charged; Consideration.....	1-14
1.11	Evaluations of Deputy Registrars.....	1-14
1.12	Required Information and Documentation.....	1-15
	Personal Background.....	1-15
	Documentation from Individuals.....	1-15
	Warning.....	1-16
	Documentation from County Auditors and Clerks of Courts.....	1-16
	Documentation from Nonprofit Corporations.....	1-16
1.13	Equipment and Facility Requirements.....	1-16
	Office Furniture, Equipment and Supplies.....	1-16
	Security Requirements.....	1-17
	Counters.....	1-18
	Signs.....	1-18
	Facility Maintenance.....	1-18
	Special Provisions for Certain BMV Controlled Sites.....	1-18
1.14	Start-Up Cost Deposit.....	1-18
	Financial Capability.....	1-18
	Acceptable Accounts.....	1-18
	BMV Controlled Sites.....	1-18
1.15	Selection Process.....	1-19
	General.....	1-19
	Request for Proposals.....	1-19
	Requirements for Proposal Submission.....	1-19
	Forms.....	1-19
	Acceptable Documents.....	1-20
	Unacceptable Documents.....	1-20
	Submission.....	1-20
	Limitation of Number of Proposals.....	1-20

TABLE OF CONTENTS

<u>Section 1</u>	Request for Proposals	<u>Page</u>
1.15	Selection Process (Cont'd.)	1-20
	Multiple Proposals.....	1-20
	Previous Proposals Not Incorporated	1-21
	Documents.....	1-21
	Deadlines.....	1-21
	Scoring Systems	1-21
	Evaluation.....	1-21
	Review by Proposers.....	1-22
	Copies of Proposals	1-22
	Written Response and Comments	1-22
	Purpose of Written Response and Comments	1-22
	Submission of Written Response and Comments	1-22
	Limitation of Communications	1-23
	RFP Email Inquiry System.....	1-23
	Consideration of Proposals.....	1-23
	Clarification of Proposals.....	1-23
	Disqualification	1-23
	Selection.....	1-24
	Beginning Operations.....	1-24
	Supplements and Amendments to RFP	1-24
1.16	Minority Business Enterprise (MBE) Certified Proposers	1-24
1.17	Timelines and Deadlines	1-25
1.18	Submission Requirements	1-26
<u>Section 2</u>	Appendices	
2.1	Additional Requirements for Deputy Provided Sites	15 pages
2.2	Ohio Administrative Code Rules – Chapter 4501:1-6 Registrars and Deputy Registrars.....	1 page
2.3	Ohio Revised Code – Selected Laws.....	1 page
2.4	Sample Agency Specifications (Actual Agency Specifications Supplied Separately).....	3 pages
2.5	Table of Contents, 2026 Deputy Registrar Contract	3 pages
2.6	2026 Deputy Registrar Contract Terms and Conditions	24 pages
<u>Section 3</u>	Personal Forms – on BMV Website: bmv.ohio.gov/dr-rfp.aspx	
3.0	Personal Checklist	1 page
3.1	Personal Questionnaire.....	6 pages
3.2	Business and Employment Experience	4 pages
3.3	Customer Service Experience.....	1 page
3.4	Start-Up Cost Funds on Deposit.....	1 page
3.5	Political Contributions Report.....	1 page
3.6	Personnel Policy	1 page
3.7	Security Plan.....	1 page

TABLE OF CONTENTS

3.8	Facility Maintenance Plan	1 page
3.9	Involved and Invested in Your Business	3 pages
3.10(A)	Affidavit of Individual.....	1 page
3.10(B)	Affidavit of County Auditor or Clerk of Courts.....	1 page
3.10(C)	Affidavit of Nonprofit Corporation	1 page

Section 4 **Operational Forms – on BMV Website: bmv.ohio.gov/dr-rfp.aspx**

4.0	Operational Checklist	1 page
4.1	Appointment of Agency Managers	1 page
4.2	Experienced Employees Summary.....	1 page
4.3	Staffing and Personnel Calculation	1 page
4.4	Start-Up Costs Calculation.....	1 page
4.5	Deputy Registrar Contract.....	2 pages

ADDITIONAL FORMS NEEDED FOR DEPUTY PROVIDED SITES ONLY:

Section 5 **Site Forms (Deputy Provided Sites Only) – on BMV Website: bmv.ohio.gov/dr-rfp.aspx**

5.0	Deputy Provided Site Checklist	1 page
5.1	Site Questionnaire	5 pages
5.2	ADA Checklist	7 pages
5.3	Lease Option.....	2 pages
5.4	Proximity Attachment (Deputy Provided Proximity Sites Only).....	2 pages

AGENCY SPECIFICATIONS: In addition to the above you will need the agency specifications for each location you are interested in (supplied separately).

**STATE OF OHIO
DEPARTMENT OF PUBLIC SAFETY
BUREAU OF MOTOR VEHICLES**

REQUEST FOR PROPOSALS FOR DEPUTY REGISTRAR APPOINTEES - 2026

1.1 PURPOSE

The purpose of this Request for Proposals (RFP) is to solicit proposals from individuals, nonprofit corporations, county auditors, and county clerks of court that meet the criteria outlined within the RFP to serve as deputy registrars for the Ohio Bureau of Motor Vehicles (BMV).

1.2 BACKGROUND

The BMV is responsible for licensing persons to operate motor vehicles, for the licensing (also known as the registration) of motor vehicles, and for other functions prescribed by law. The authority of the BMV is vested in the Registrar of Motor Vehicles (Registrar), who is appointed by and reports to the Director of Public Safety (Director). The Registrar appoints various assistants, deputies, and employees as deemed necessary to administer the law.

1.3 AUTHORITY

The Registrar, with the approval of the Director, appoints deputy registrars throughout the eighty-eight counties of Ohio. The Registrar may appoint private individuals, nonprofit corporations, **county clerk of a court of common pleas, and county auditors** as deputy registrars. The Registrar intends to exercise discretion in selecting or otherwise awarding contracts to those who, in the Registrar's opinion, will best serve the interests of the State of Ohio and its citizens. In coming to a decision to award a contract, the Registrar may use any fair, objective and reasonable criteria for determining which applicant is the best qualified to serve as a deputy registrar; the past performance of any deputy registrar seeking reappointment may be taken into consideration by the Registrar in arriving at a decision in this selection process. The Registrar may, but is not required to, use a scoring system or other evaluation devices in arriving at a decision. The Registrar shall make these decisions without regard to political affiliation or contributions.

Where feasible, the Registrar will also seek to set up one-stop shopping. "One-stop shopping" means that the deputy registrar agency will be located in the same facility as, or close to, a driver license examination station ("exam station"), or a clerk of courts title office ("title office"), or both.

1.4 SERVICES TO BE PERFORMED

Upon appointment, deputy registrars will be required to perform services as indicated in the Ohio Revised Code (ORC), the Ohio Administrative Code (OAC), this RFP, the Deputy Registrar Manual, the deputy registrar contract to be signed (form included in this RFP package), the services indicated in the Agency Specifications for the particular location, and any other directives issued by the authority of the Registrar. A separate set of Agency Specifications is issued for each location, and must be downloaded from the [BMV Website](#).

Administrative rules. At minimum, each proposer should become familiar with OAC [4501:1-6-01](#) governing deputy registrar contracts, OAC [4501:1-6-02](#) governing the selection and appointment of deputy registrars, and OAC [4501:1-6-03](#) governing the designation of locations and sites. Links to these rules and OAC [4501:1-6-04](#) governing limited authority deputy registrars are included as Appendix 2.2 of this RFP.

General duties. The deputy registrars' duties shall include, but are not limited to: issuing motor vehicle registrations; administer duties related to the issuance of drivers' licenses, commercial drivers' licenses, motorcycle operators' licenses, and State of Ohio identification cards; administering motor vehicle inspections; conducting vision screenings; administering declarations regarding anatomical organ donations; administering statutory donation programs; conducting voter registrations; providing information on optional mail-in vehicle registration; collecting next of kin information, providing certain public information and providing other services as specified by law and as directed by the Registrar. Deputy registrars must be able to perform all license agency transactions. In instances where clerks of court, county auditors, or nonprofit corporations are appointed as deputy registrars, the office manager must be able to perform all license agency transactions. BMV field staff will be authorized to conduct periodic testing to verify this proficiency.

Nature of the contract. The contract between the Registrar and each deputy registrar is in the nature of a non-exclusive, limited franchise agreement. It is in the nature of a franchise agreement because deputy registrars are authorized to perform governmental licensing functions on behalf of the Registrar and the State of Ohio and because deputy registrars are independent contractors and not employees of the State. The franchise is non-exclusive because there is no protected franchise territory and the Registrar may establish additional deputy registrar agencies at any time the Registrar deems it advisable. The franchise is limited because each contract terminates absolutely at the end of a definite contract period of five years unless the Registrar specifies a shorter period. Prior to the expiration of any deputy registrar contract, the registrar, with the approval of the director, may award a one-year contract extension to any deputy registrar who has provided exemplary service based upon objective performance evaluations. At the end of each contract period, an incumbent deputy registrar may compete for a new deputy registrar contract. It is essential that each proposer become familiar with the terms of the deputy registrar contract.

1.4 SERVICES TO BE PERFORMED (Cont'd.)

Other competitive factors. The BMV will continue to offer vehicle registration and other services by mail, telephone and over the Internet ([OPLATES](#) for example). Pursuant to ORC [4503.036](#), the BMV has established limited authority deputy registrars (LADRs). LADRs are certain clerk of courts and motor vehicle dealers who are authorized to process motor vehicle registrations for customers at the time they are transferring a vehicle and applying for a certificate of title. These activities may affect the number of transactions conducted by deputy registrars. In addition, the BMV may explore alternative methods to issue and provide driver licenses, identification cards, vehicle registrations and other BMV-related services.

1.5 AGENCY SPECIFICATIONS

This document (the RFP) contains the information common to all proposals for all locations. In addition to this RFP, the Registrar has prescribed a separate set of specifications for each deputy registrar agency. Those specifications are generally referred to as "Agency Specifications." "Appendix 2.4" contains a sample set of Agency Specifications for one agency. No proposal can be complete without reference to both this RFP and the Agency Specifications for the deputy registrar agency being proposed. The Agency Specifications include the geographic area in which the agency will be located unless approved otherwise, the size of the agency, a history of recent transactions, applicable fees, and the type of site.

Geographical area. "Location," as used in this RFP, means the area specified and described in the Agency Specifications in which the proposed deputy registrar agency site must be located or within close proximity of. "Site," as used in this RFP, means the precise address proposed for the deputy registrar agency. The specified and described location in the Agency Specifications may be restricted by the BMV to a single site designated as a "BMV Controlled Site."

Type of site. Sites are divided into two major categories: (1) BMV Controlled Sites, and (2) Deputy Provided Sites.

BMV Controlled Sites. A "BMV Controlled Site" is one in which the BMV will designate the exact site where the deputy registrar agency will be located. The BMV will arrange a master lease for the site. The master lease may be held by the BMV itself or a county (in conjunction with a clerk of courts title office). All otherwise qualified persons are eligible to submit a proposal for a BMV Controlled Site. The successful proposer will be required to sublease space from the entity holding the master lease and to operate the deputy registrar agency at that, and only that, site.

1.5 AGENCY SPECIFICATIONS (Cont'd.)

Deputy Provided Sites. A “Deputy Provided Site” is one in which the successful proposer will be required to provide, through lease or ownership, the site where the deputy registrar agency will be operated. In some locations, the proposer will be encouraged to locate the deputy registrar agency close to an existing driver license examination station or clerk of courts title office. In other locations, the proposer will be asked to locate the deputy registrar agency without regard to any driver license examination station or clerk of courts title office. Appendix 2.1 lists the additional requirements for Deputy Provided Sites in detail.

Proposers applying for contracts at existing license agency locations designated as Deputy Provided Sites that were previously approved, are required to complete form 5.0 (Deputy Provided Site Checklist), page one (1) of form 5.1 (Site Questionnaire), **and form 5.3 (Lease Option)**. Additional information must be provided if there have been any changes to the site or any other items identified in the Section 5 (5.0 through 5.4) forms, including the Site Plan.

Estimated annual transactions. The Agency Specifications for each proposed deputy registrar location contain an estimate of the number of transactions that location processed in a recent twelve-month period. This estimate may be used in conjunction with the statutory fee schedule to calculate an estimate of the gross annual income. The BMV makes no effort to estimate the net profits any agency may be expected to make. Each proposer is responsible for determining whether or not the agency is likely to generate a sufficient profit for that proposer’s needs.

Agency size and staffing. The Registrar establishes agency size and corresponding requirements based on the estimates of the number of transactions each agency is likely to process on an annual basis. These factors are listed in the Agency Specifications for each location. The following chart shows the basic requirements for each class of agency based on size:

1.5 AGENCY SPECIFICATIONS (Cont'd.)

Annual Transactions	Agency Class Size	Computer Terminals	*Recommended Weekly Staff Hrs.	Minimum Parking Spaces	Minimum Sq. Ft.
0-20,000	1	1-2	102	7	—
20,001-35,000	2	1-2	102	7	630
35,001-40,000	3	2-3	107	14	830
40,001-45,000	3	2-3	121	14	830
45,001-50,000	3	2-3	134	14	830
50,001-55,000	4	2-3	147	14	830
55,001-60,000	4	2-3	161	14	830
60,001-65,000	5	3-4	174	21	1,080
65,001-70,000	5	3-4	188	21	1,080
70,001-75,000	5	3-4	201	21	1,080
75,001-80,000	6	4-5	214	28	1,340
80,001-85,000	6	4-5	228	28	1,340
85,001-90,000	6	4-5	241	28	1,340
90,001-95,000	7	5-6	255	35	1,620
95,001-100,000	7	5-6	268	35	1,620
100,001-105,000	7	5-6	281	35	1,620
105,001-110,000	7	5-6	295	35	1,620
110,001-115,000	7	5-6	308	35	1,620
115,001-120,000	7	5-6	322	35	1,620
120,001-125,000	8	6-7	335	42	1,930
125,001-130,000	8	6-7	348	42	1,930
130,001-135,000	8	6-7	362	42	1,930
135,001-140,000	8	6-7	375	42	1,930
140,001-145,000	8	6-7	389	42	1,930
145,001-150,000	8	6-7	402	42	1,930
150,001-155,000	8	6-7	415	42	1,930
155,001-160,000	8	6-7	428	42	1,930
160,001-175,000	8	6-7	441	42	1,930
175,001-190,000	8	6-7	454	42	1,930

The following is a brief explanation of the above chart.

“**Annual Transactions**” refers to the total number of driver licenses, commercial driver licenses, temporary permits, identification cards, motor vehicle registrations, driving record abstracts, physical inspections and salvage inspections issued by the agency in a twelve-month period.

“**Agency Class Size**” refers to the general size of the agency with Class 1 being the smallest and Class 8 being the largest.

“**Computer Terminals**” refers to the number of computer workstations the BMV will supply to the agency to process driver license, vehicle registration, and other transactions. In addition to these computer terminals, the BMV also supplies a computer system, which produces Ohio driver licenses and identification cards containing a digitized photographic image.

1.5 AGENCY SPECIFICATIONS (Cont'd.)

“Recommended Weekly Staff Hours” refers to the requirement that the deputy registrar schedule enough employees to work at the agency during regular business hours, calculated on a weekly basis. There is a general requirement that each agency must have at least two employees on duty at all times the agency is open for business. The hours the deputy registrar himself or herself spends working during regular business hours counts toward the total hours required. Deputy registrars are encouraged to schedule the employees so that more employees are working at the busiest periods and fewer employees are working during slower periods.

Recommended license agency weekly staffing hours may be increased or reduced from time to time, upon request by deputy registrars, and approval by the Registrar, based on an increase or decrease in transaction volumes. Any such requests are subject to review, evaluation and approval by the Registrar and shall be considered on a case-by-case basis. Proposers may elect to use the recommended staffing hours supplied by the BMV when completing proposal(s) or may establish their own detailed staffing hours plans, which may contain more or less than the number of staffing hours recommended by the BMV-provided specifications. However, the BMV reserves the right to enforce its recommended weekly staffing hour requirements, at any time, if any license agency location is not providing adequate customer service and is discovered to be routinely exceeding reasonable wait times.

“Minimum Parking Spaces” refers to the minimum number of parking spaces, which must be available to agency customers. All agencies must make disability parking available also. For BMV Controlled Sites, the BMV will be responsible for this requirement. At Deputy Provided Sites, the deputy registrar is responsible for full compliance. For those sites, additional information is contained in Section 5.

“Minimum Square Footage (Sq. Ft.)” refers to the minimum floor space available in the agency. The BMV is responsible for this in BMV Controlled Sites. The deputy registrar is responsible at Deputy Provided Sites; additional information is provided in Section 5 for those sites.

Non-exclusive territories. The Registrar may set up deputy registrar locations in any areas as the Registrar, with the approval of the Director, sees fit. A deputy registrar has no rights in the contract past its expiration date, nor does a deputy registrar have exclusive territorial rights during the term of the contract.

Changes to number of agencies. The Registrar may abolish an agency at any location at any time that it is not under contract, including after an RFP has been issued and before the Registrar actually signs the contract. The Registrar may add deputy registrar agencies in any county at any time at the Registrar’s discretion.

1.5 AGENCY SPECIFICATIONS (Cont'd.)

Bond Requirements. The amount of the bond required is set at \$25,000.00 for all license agencies. Clerks of court and county auditors may be permitted to fulfill the bond requirement by including the BMV on an existing county bond as an additional insured, as long as the county bond sufficiently protects the State, ODPS, and BMV from any acts of dishonesty by the deputy registrar and any or all of the deputy registrar's employees. **Clerks of court and county auditors may also utilize CORSA General Liability Insurance instead of an Individual Surety Bond.**

Other information. Other information regarding each proposed deputy registrar agency may be described in the Agency Specifications.

1.6 EXCLUSIONS AND QUALIFICATIONS

Exclusions. The statutes and administrative rules prohibit the appointment of certain persons as deputy registrars.

1. **No contract shall be awarded to any elected public official** other than a county auditor, or a clerk of a court of common pleas. However, the Registrar shall continue and may renew a contract with any deputy registrar who, after being awarded a deputy registrar contract, is elected to an office of a political subdivision in accordance with ORC [4503.03](#).
2. **No contract shall be awarded to any parent, child, brother, or sister of any deputy registrar** if the relative is living in the same household as the deputy registrar.
3. **No contract shall be awarded to the spouse of any deputy registrar**, whether or not living in the same household. A husband and wife may both submit proposals; however, only one may be appointed.

1.6 EXCLUSIONS AND QUALIFICATIONS (Cont'd.)

5. No contract shall be awarded to any person, if that person, or, where applicable, that person's spouse or an immediate family member, has made in the current calendar year (2026) or in any one of the previous three calendar years (2023, 2024, 2025) one or more contributions totaling more than one hundred dollars (\$100.00) to any one of the following:
 - A. Any political party (contributions to a political party at the local, state, and national levels and must also include all contributions to continuing associations and political action committees (PACs) associated with that political party);
 - B. Any candidate for the office of governor, attorney general, secretary of state, treasurer of state, auditor of state, member of the senate or house of representatives of the general assembly; or
 - C. Any campaign committee for any candidate listed above.

The limitations of this section do not apply to any county auditor or a clerk of a court of common pleas, or to a deputy registrar who is elected to an office of a political subdivision after he or she is awarded a deputy registrar contract.

6. **No contract shall be awarded to any employee of the State of Ohio.** However, a contract may be awarded to a present employee of the State of Ohio if that employee certifies in the proposal that he or she will resign from state employment upon appointment to a deputy registrar contract.
7. **No contract shall be awarded to the spouse, parent, child, brother, sister, father-in-law, mother-in-law, brother-in-law, sister-in-law, son-in-law, or daughter-in-law of any employee of the Department of Public Safety, the Bureau of Motor Vehicles, or the State Highway Patrol,** except as provided in OAC [4501:1-6-01](#)(M).
8. **No contract shall be awarded to an agent for an insurance company, writing automobile insurance.** This provision does not apply to nonprofit corporations. A licensed insurance agent may be appointed if he or she agrees not to engage, directly or indirectly, in the insurance business during the entire term of the contract.
9. **No contract shall be awarded to any person who holds a current, valid contract to conduct EPA motor vehicle emissions inspections** under ORC [3704.14](#).
10. **No contract shall be awarded to any person who has been convicted within the past ten years** of a crime punishable by death or a crime punishable by imprisonment in excess of one year (felonies), or any crime involving dishonesty or false statement.
11. **No contract shall be awarded to any for-profit corporation.**
12. **No contract shall be awarded to any partnership or any other business association** except a nonprofit corporation.

1.6 EXCLUSIONS AND QUALIFICATIONS (Cont'd.)

Nonprofit corporations may be awarded a contract. A nonprofit corporation may be awarded a deputy registrar contract. To qualify, a nonprofit corporation shall submit and maintain at all times during the term of the contract appropriate documentation showing good standing as a nonprofit corporation as defined in ORC [1702.01](#). Special instructions apply to proposals submitted by nonprofit corporations.

Residency requirements. Prior to the award of a contract, the person appointed shall give evidence, satisfactory to the Registrar, that he or she is legally entitled to work in the United States of America. Each individual deputy registrar shall occupy a primary residence within the State of Ohio. As used herein, "primary residence" means a residence that meets all of the following: it is the place where the deputy registrar customarily lives; the one place that is the deputy registrar's true, principal, and permanent home; and the place he or she intends to remain. If the deputy registrar is a nonprofit corporation, it shall maintain a place of business within the county in which each of its agencies are located. The Registrar may, after notice, terminate the contract of any deputy registrar who violates these provisions.

1.7 NO POLITICAL CONSIDERATIONS

The Registrar shall not award a deputy registrar contract to a person, or promise to do so, because that person pays an assessment or subscription to, or makes a contribution to, any political party, the Governor or the Governor's campaign committee, or any candidate for public office or his or her campaign committee. The Registrar shall not withhold a deputy registrar contract from a person, or threaten to do so, because that person fails to pay an assessment or subscription to, or fails to make a contribution to, any political party, the Governor or Governor's campaign committee, or any candidate for public office or the candidate's campaign committee.

Political contribution limitations. The successful deputy registrar proposer will be required to comply with the contract regarding political contribution limitations and prohibitions. The proposer will be required to sign a statement under oath that he or she is eligible to be a deputy registrar in accordance with the provisions of ORC [4503.03\(B\)](#) and the OAC.

Explanation of political contribution limitations. The "family" political contribution limitation (family limitation) is \$100.00 per candidate and \$100.00 per political party per year. Family contributions totaling \$100.00 or less per candidate per year or per party per year are acceptable; family contributions totaling \$100.01 or more per candidate or \$100.01 or more per party in any calendar year exceed the family limitation and make you ineligible for a deputy registrar contract.

"Family political contribution" means for each particular party and each particular candidate, you must add together your own contributions, your spouse's contributions, and your dependent children's contributions to that one political party or to that one candidate.

1.7 NO POLITICAL CONSIDERATIONS (Cont'd.)

You must include all contributions (yours, your spouse's and your dependent children's) for each of the last three calendar years (2023, 2024, 2025) separately and for this calendar year (2026) to date.

You must add together all contributions to a political party at the local, state, and national levels and must also include all contributions to continuing associations and political action committees (PACs) associated with that political party.

The limitation applies to each individual candidate for Governor, Attorney General, Secretary of State, Treasurer of State, Auditor of State, State Senator, or State Representative (State House of Representatives) and the campaign committee of each. There are no limitations on contributions to candidates for national, county, municipal, township, school board, or judicial offices.

ORC [4503.033](#) requires that every deputy registrar will file, along with a twenty-five dollar filing fee, before the thirty-first day of January each year, a statement that discloses all contributions made by the deputy registrar, or his or her spouse or an immediate family member, to any political party, any candidate for statewide office or such a candidate's campaign committee, and the value, in dollars and cents of each contribution. A county auditor or a clerk of a court of common pleas is not required to file this disclosure statement or to pay the filing fee.

Form 3.5, Political Contributions Report, is intended to assist you in determining whether or not you have exceeded the political contributions limitations.

1.8 REQUIREMENTS OF OPERATION

General. The deputy registrar will be expected to comply with the provisions of this RFP, the ORC, the OAC, the Deputy Registrar Contract, the Deputy Registrar Manual, and any requirements prescribed by the Registrar from time to time. In addition, the deputy registrar shall comply with all applicable federal and Ohio laws, including but not limited to the Federal Equal Employment Opportunity (EEO) Laws, and the Americans with Disabilities Act (ADA).

Office hours. The deputy registrar shall maintain office hours as required by the Registrar. These requirements may change from time to time. By proposing under this RFP, the proposer is indicating a willingness to follow those requirements.

Computers and BMV-supplied equipment. The BMV supplies the computers and related equipment (printers, scanners, camera, etc.) necessary to process driver license applications, driver licenses, Ohio identification cards, and motor vehicle registrations.

Inventory. The BMV also supplies inventories of license plates, validation and county stickers, and many of the forms necessary to transact BMV business. The deputy registrar is responsible to maintain and order adequate, but not excessive, inventory. The BMV will pay transportation expenses for routine inventory deliveries. The deputy registrar shall pay for any additional transportation and delivery expenses caused by the deputy registrar's ordering too much or too little inventory.

1.8 REQUIREMENTS OF OPERATION (Cont'd.)

Other Expenses owed to the BMV. There is no charge to the deputy registrar for the use of the computer equipment supplied by the BMV. The Registrar may charge deputy registrars for the use of vision screening equipment in accordance with ORC [4507.12](#) and OAC [4501:1-6-01](#)(F), which is currently a rate of ten cents per screening. In addition, deputy registrars may be required to pay the Registrar counter and alarm system expenses as specified in Section 1.13.

Deputy registrar responsibilities. The deputy registrar shall be required to accomplish routine care of the equipment provided by the BMV, as prescribed by the manufacturer and the Registrar, in order to ensure that it continues in good working order, including but not to be limited to, daily cleaning of equipment and routine inspection for and removal of any debris that may impede or prevent the correct operation of any equipment. The deputy registrar shall be responsible for the cost of repairs to the equipment when damage is due to fault on his or her part or that of his or her employees. The deputy registrar shall ensure that the license agency is free of potential fire and safety hazards at all times. The deputy registrar shall be personally and strictly liable for the consignment value of all license plates, stickers, all other inventory, and State-owned equipment issued by the BMV.

Insurance, reimbursement, and hold-harmless. Each deputy registrar shall maintain during the entire term of the contract a policy of business liability, property damage, and theft insurance satisfactory to the Registrar, and shall hold the Department of Public Safety, the Director of Public Safety, the Bureau of Motor Vehicles, and the Registrar harmless upon any and all claims for damages or losses arising out of the operation of the deputy registrar agency. The “hold harmless” clause does not apply to county officials.

The “policy” shall include coverage of at least \$50,000.00 for BMV property with the Ohio BMV to be added as the second named insured; minimum coverage of \$250,000.00 for personal liability; and the Ohio BMV is to be notified immediately of any policy cancellation.

Bonding. The successful proposer will be required, as outlined in OAC [4501:1-6-01](#) (B), to obtain bonding sufficient to protect the interests of the State of Ohio from losses due to fraud, theft, embezzlement, and any other improprieties by the deputy registrar or the deputy registrar’s employees that may cause a shortage of State funds. In order to propose, the proposer must be bondable under these requirements. All proposers, including incumbent deputy registrars proposing, are required to provide, as part of their proposal, a statement disclosing pre-approval status for a bond in the amount of twenty-five thousand dollars (\$25,000.00) from a reputable and verifiable bonding or insurance company. The contract terms and conditions contain more detailed information about bond requirements.

1.8 REQUIREMENTS OF OPERATION (Cont'd.)

The Registrar may adjust the amounts of the bond if there is good cause to do so. However, the amount of the bond shall not be increased during the term of this contract. The bond shall be purchased by the deputy registrar naming the State of Ohio, Department of Public Safety (ODPS), Bureau of Motor Vehicles (BMV), as the bondholder, insured, or additional insured, on the bond itself, in a rider or in an add-on. The bond shall protect the State, ODPS, and BMV from any acts of dishonesty by the deputy registrar and any or all of the deputy registrar's employees. Any delinquency, default, or cancellation of bond coverage shall be reported immediately by the bonding company to the Bureau of Motor Vehicles, Registrar's Office, P.O. Box 16520, Columbus, Ohio 43216-6520.

Banking specifications. No less than one week prior to the start of any deputy registrar contract, the deputy registrar shall establish an account in full compliance with the banking requirements contained in the contract and Deputy Registrar Manual.

Credit and debit cards, etc. Pursuant to R.C. [4503.102\(H\)](#), the BMV has implemented the acceptance of financial transaction devices (credit cards, debit cards, charge cards, prepaid or stored value cards, etc.) in payment of state taxes and fees and deputy fees directly related to official BMV transactions only. The implementation of financial transaction devices does not prohibit the use of automated transaction machines (ATMs) within the deputy registrar agencies.

Prohibition against commingling. The monies collected by the deputy registrar from sales of items consigned by the State shall be deposited into the State account. The deputy registrar shall not commingle this money with funds from any other account.

Telephone accessibility. The deputy registrar shall maintain telephone service and accessibility as required by the ORC, the OAC, the Contract, the Deputy Registrar Manual, and any other requirements prescribed by the Registrar.

Emergencies. The deputy registrar shall make arrangements regarding emergencies, as required by the contract.

1.9 EMPLOYEES

General. Good employees are essential to the successful operation of a deputy registrar agency. Your proposal should contain information showing that you have an understanding of personnel issues and that you will hire, train, and maintain a full staff of competent employees. Selecting "Yes" on Form 3.6 means your personnel policy meets all the essential personnel requirements. Use Form 4.1 to address your appointment of agency managers, Form 4.2 to list experienced employees, and Form 4.3 to show the projected total number of employees you intend to employ, projected number of hours worked each week, and projected hourly rate of pay, weekly pay, and monthly pay.

1.9 EMPLOYEES (Cont'd.)

Bilingual employees. In locations where the deputy registrar serves a substantial immigrant population, the deputy registrar shall make every reasonable effort to employ bilingual employees who are fluent in English and in the predominant language of the limited English proficiency speaking population in that area.

Personnel policy. Each proposer shall develop and submit, upon request, a comprehensive written personnel policy. The personnel policy must be complete and comprehensive; a summary alone is not acceptable. If awarded a contract, the proposer shall maintain, enforce and modify, as necessary, the personnel policy throughout the term of the contract. At minimum, the personnel policy shall include a detailed section addressing each of the following areas:

1. Employee hiring, including provisions for hiring employees experienced in deputy registrar agency employment;
2. Equal Employment Opportunity compliance provisions;
3. Staff training, including attendance of training offered by the BMV;
4. Additional training to be provided by the deputy registrar to his or her employees;
5. Periodic (annual at minimum) evaluations (documented) of employee performance;
6. A disciplinary plan including a list of grounds for discipline and dismissal, **which shall include but is not limited to drug and alcohol use**;
7. The BMV expects that the deputy registrar will use a progressive disciplinary process;
8. A specific dress code, including a specific list of acceptable attire, unacceptable attire, and a policy for maintaining the professional appearance of all staff at all times.

In addition, the personnel policy should list fringe benefits, if any, offered to employees. Fringe benefits do not include benefits that are required by the contract or by law. Additional fringe benefits are not required, but proposers offering additional fringe benefits may be evaluated more favorably.

Failure to submit, upon request, a detailed and comprehensive personnel policy will most likely result in an unfavorable evaluation.

Training. The deputy registrar and the employees of the deputy registrar shall attend all necessary training sessions as prescribed by the Registrar and shall pay all travel and meal expenses incurred. The cost of all BMV-conducted training (tuition) shall be borne by the BMV. All deputy registrars and license agency employees are required to receive comprehensive training in license agency business operational policies, procedures, and practices prior to independently performing any type of license agency transactions. Comprehensive training shall include, but not be limited to, mandatory BMV fraudulent identification training, new legislated or BMV-initiated process and procedures training, and any other training determined by the BMV to be necessary for operating a deputy registrar license agency business.

1.9 EMPLOYEES (Cont'd.)

Office management. The deputy registrar shall be regularly scheduled and shall work at the agency at least twenty (20) hours per week during regular business hours. In addition, the deputy registrar shall appoint a full-time office manager, who shall be on duty at the agency at least thirty-six (36) hours per week, and who shall be responsible for agency operations during any absences of the deputy registrar. The deputy registrar shall also appoint an assistant office manager. The assistant office manager shall supervise the agency when both the deputy registrar and the office manager are absent. The deputy registrar may appoint himself or herself as the office manager. Any deputy registrar who serves as the office manager must also meet the thirty-six (36) hours per week requirement. It is upon the proposer to explain to the BMV exactly how they will be invested and involved in the license agency business. These requirements do not apply to county auditors, clerks of courts, **or deputy registrars operating multiple locations (assessed as received).**

Employee standards. The deputy registrar, at the deputy's own expense, will be required to obtain Ohio Bureau of Criminal Investigation (BCI) and Federal Bureau of Investigation (FBI) criminal background reports for all deputy registrar employees. See the contract terms and conditions for more detailed information. The deputy registrar must also conduct employment reference checks of potential employees prior to hire. It is the deputy registrar's responsibility that employees perform the duties of their employment and be knowledgeable in all applicable laws and regulations pertaining to the operation of a deputy registrar agency, and that they perform their duties in a competent, professional, efficient, and friendly manner.

Staffing levels. In accordance with the contract, the deputy registrar shall be responsible for properly staffing his or her agency to meet the volume of customers. See RFP Section 1.5 and the Agency Specifications.

Employee age requirement. Persons under 18 years of age are not permitted to work in deputy registrar license agencies **in a position that requires a background check or computer compliance agreement.**

1.10 FEES TO BE CHARGED; CONSIDERATION

The deputy registrar shall charge those fees and only those fees, no more and no less, provided in the ORC and/or OAC for statutory services. The deputy registrar shall turn over all amounts as required to the BMV and shall retain the statutory service fees in consideration for services rendered as provided under this contract.

1.11 EVALUATIONS OF DEPUTY REGISTRARS

The deputy registrar shall be subject to periodic evaluations by one or more persons designated by the Registrar for compliance with requirements imposed by the ORC, by the OAC, the contract, the Deputy Registrar Manual, or by direction of the Registrar. Unsatisfactory evaluations may result in liquidated damages to be owed to the BMV, in accordance with the contract and OAC [4501:1-6-01\(C\)](#). Unsatisfactory evaluations may also result in the termination of the contract during its term or ineligibility for future contracts in accordance with OAC [4501:1-6-02](#). Prior to the expiration of any deputy registrar contract, the Registrar, with the approval of the Director, may award a one-year contract extension to any deputy registrar who has provided exemplary service based upon objective performance evaluations.

1.12 REQUIRED INFORMATION AND DOCUMENTATION

Personal background. The proposal shall contain the following information on the Personal Questionnaire, Form 3.1: the proposer's name, home address, daytime and home telephone numbers, driver license number, business and work experience, and other information as prescribed by the Registrar. For nonprofit corporations, the information relates to the nonprofit corporation itself, not to any employee of the nonprofit corporation.

Documentation from individuals. As part of the proposal, each individual proposer is required to submit:

- (1) **A credit report** dated during calendar year 2026 covering the proposer's current credit status. You must submit your credit report with your proposal. We will not accept credit reports **emailed** separately from your proposal. Credit reports must be complete and **shall include a credit score** supplied by one of the recognized score providers such as: VantageScore, PLUS, Risk Score, or Fair Isaac Corporation (FICO) and shall be supplied by, at minimum, one of the three major credit-reporting agencies: Equifax, Experian, or TransUnion. Three-in-one credit reports will be accepted. Credit reports downloaded from the Internet are acceptable as well. Summary credit reports are not acceptable.
- (2) **A local arrest and conviction report** issued during 2026 from the local law enforcement agency for the jurisdiction in which you reside. The local arrest and conviction report should be available from whatever local police agency serves your community. This could be city police, village police, township police, or the county sheriff. If you have lived in your present community for less than twenty-four months, you must submit reports from both your present community and your previous community of residence. There is no standard format for these reports. The report may be on the law enforcement agency's letterhead or may be in some other form.
- (3) **Ohio and FBI criminal background reports.** Each individual proposer, county auditor, and clerk of court is required to apply for an Ohio Bureau of Criminal Investigation (BCI) and Federal Bureau of Investigation (FBI) background reports through WebCheck, an electronic criminal background reporting service offered by the Ohio Attorney General through local outlets. The WebCheck locations are listed on the Ohio Attorney General's website at the following address: <http://www.ohioattorneygeneral.gov/Business/Services-for-Business/WebCheck/Webcheck-Community-Listing>. The WebCheck facility will not provide the criminal background report directly to you; ask the WebCheck facility to send the report to: BMV Registrar's Office, Ohio Bureau of Motor Vehicles, 1970 West Broad Street, P.O. Box 16520, Columbus, OH 43216-6520. Be certain to obtain a receipt from WebCheck and submit a copy of your receipt with your Proposal. The Registrar reserves the right to require any deputy registrar or deputy registrar employee to submit a BCI WebCheck report and/or a Federal Bureau of Investigation background report at any time during the contract term.

1.12 REQUIRED INFORMATION AND DOCUMENTATION (Cont'd.)

- (4) **A pre-approval statement of eligibility for a twenty-five thousand dollar (\$25,000.00) bond.** Each individual proposer and nonprofit corporation is required to submit a pre-approval statement of eligibility for a twenty-five thousand dollar (\$25,000.00) bond, issued in 2026, from a reputable and verifiable bonding or insurance company. County auditors and county clerks of courts are required to submit a copy of the existing county blanket bond.

Warning. Failure to submit any required document or information may result in the loss of points or disqualification of the proposal, or both.

Documentation from county auditors and clerks of courts. A county auditor or clerk of courts shall submit the same information as an individual would (a WebCheck receipt and a local law enforcement arrest and conviction report) except that they are not required to submit a credit report.

Documentation from nonprofit corporations. A nonprofit corporation is not required to submit any credit report, local law enforcement arrest and conviction report, or WebCheck receipt, but shall submit instead a copy of the nonprofit corporation's:

- (1) **Articles of Incorporation;** and
- (2) A current **Certificate of Good Standing issued by the Ohio Secretary of State**, issued during the 2026 calendar year. Failure to submit current documents may result in an unfavorable evaluation or disqualification.

1.13 EQUIPMENT AND FACILITY REQUIREMENTS

Office furniture, equipment and supplies. The deputy registrar is responsible for providing all office equipment and supplies except the BMV-supplied computers, equipment, and inventory (see RFP Section 1.8). The deputy registrar is responsible for providing all office furniture for both employees and customers (desks, chairs, tables, etc.), office equipment (calculators, file cabinets, trash receptacles, shelving, etc.), and all office supplies necessary to operate the deputy registrar agency. Each deputy registrar shall supply a copy machine and a fax machine (or one machine capable of both) and at least one crosscut shredder for the deputy registrar's use and for the customers' use to securely dispose of documents containing personal information.

1.13 EQUIPMENT AND FACILITY REQUIREMENTS (Cont'd.)

Security requirements. The deputy registrar is responsible for supplying equipment necessary to keep secure all BMV funds, equipment, inventory, and records. At minimum, each deputy registrar shall supply a safe or secure locking cabinet and an acceptable, off-site monitored reporting alarm system. The alarm system shall include a feature, which automatically reports off-site if wires are cut or disconnected. The deputy registrar is responsible for assuring that all appropriate items are securely stored and locked and that the agency is secured and locked at all times the agency is not open for business. In addition, the following requirements will be imposed for license agency security: (1) installation of a monitored recording video surveillance system to sufficiently observe customer and employee activity inside of the license agency business with a sufficient number of security cameras to fully view all points of entry and exit, customer waiting area, customer service area, and all entrances to the inventory storage area, at all times; each camera must be a digital color camera with zoom capability; equipped with motion detection so that when the office is closed, the cameras will activate with motion; equipped with infrared or motion-activated lighting and repaired or replaced immediately if they become inoperable; the cameras must be operational at all times the office is open; the security camera media and hard drive must be kept secure; it is recommended that recorded video be retained for a rolling 30-day period and is required to be saved for a minimum of 14 days on a rolling calendar period; (2) installation of alarm monitored motion detectors in each room or space, including the records storage room; (3) installation of alarm contacts on all exterior points of entry, including windows that open, and an alarm contact on the door to the records storage room, if applicable; (4) installation of window vibration sensor reporting alarms or alarm monitored motion detectors for windows that could be opened or broken into and entered by an intruder; (5) installation of smoke, fire, and carbon monoxide detection devices; (6) installation of a minimum of one concealed alarm monitored panic/hold-up button under counters between every two computer terminals provided or, if approved by the Registrar, an alternate key fob activated panic/hold-up device; (7) each employee authorized to turn off the alarm system must have a unique security code or biometric code; (8) the security alarm company must be able to provide reports to show by whom and when the alarm was turned on, turned off, and the time and location within the facility of any intrusion; (9) the security alarm company must automatically notify local law enforcement and the deputy registrar to respond if the alarm is set off; (10) all license agencies will provide a crosscut shredder to be made readily available to all customers for the destruction of any customer copies of records that contain personal information about the customer; (11) all records that have exceeded the retention period must be shredded on-site; and (12) provisions for safeguarding (erase/destroy/remove/reformat) all hard drive data (including images) stored on copiers, scanners, and facsimile devices used in the license agency for business purposes when the equipment is disposed, salvaged, sold, recycled, auctioned or otherwise removed from the license agency business. The security system and cameras must be diagnostically tested monthly and verification of operating condition shall be made available to BMV staff for review. The BMV reserves the right to require more or less security measures whenever and wherever needed.

1.13 EQUIPMENT AND FACILITY REQUIREMENTS (Cont'd.)

Counters. The deputy registrar is responsible for providing counters to accommodate the BMV supplied equipment to serve customers in a convenient manner, and to accommodate the efficiency and comfort of the deputy registrar's employees. The Registrar may change these specifications from time to time, and the deputy registrar shall comply with any changes in specifications unless the Registrar grants a variance for good cause.

Signs. The deputy registrar shall ensure that the agency is well marked, with adequate signs to enable potential patrons to locate the agency conveniently. The signs identifying the deputy registrar agency shall be sufficient to identify the agency, shall comply with all applicable zoning requirements, and shall include at least one outside sign. Sign specifications and provisions are contained within the Deputy Registrar Manual. The Registrar may change these specifications from time to time, and the deputy registrar shall comply with any changes in specifications.

Facility maintenance. The deputy registrar shall adopt an acceptable facility maintenance plan and shall be responsible for ensuring that the interior and exterior of the deputy registrar agency premises are maintained in a clean, safe, and attractive condition at all times. The facility maintenance plan shall, at minimum, provide that any carpeting and/or flooring be professionally cleaned as needed and no less than once per year, and that the walls be maintained at all times and be repainted at least once during the term of the contract.

Special provisions for certain BMV Controlled Sites. For certain BMV Controlled Sites, the BMV may make arrangements for the installation of an off-site monitored alarm system, the construction or modification of counters, the installation or modification of signs, any other mandatory equipment, and any or all equipment furnishings required to ensure the comfort of the customers and employees. The deputy registrar shall pay for or reimburse the BMV for any such improvements at the BMV's actual costs (usually on an amortized basis) and shall be responsible for maintaining those improvements during the term of the contract.

1.14 START-UP COST DEPOSIT

Financial capability. The proposer must be able to demonstrate that he or she is financially capable of establishing a deputy registrar agency. The proposer shall have funds on deposit, in the proposer's own name, to cover the estimated costs of: (1) site preparation costs, if appropriate; (2) agency rental payments for the first three months; and (3) one month's personnel costs, all as calculated on Form 4.4, Start-Up Costs Calculation. If the proposer is awarded a contract, the proposer shall maintain the funds on deposit for the actual payment of start-up costs. If no contract is awarded, the funds may be withdrawn.

Acceptable accounts. The funds must be on deposit in the name of the proposer only (or the proposer and the proposer's spouse only) in an established account in a bank, a savings and loan institution, or credit union. Brokerage accounts, mutual funds, stocks, lines of credit, credit cards, etc., are not acceptable.

BMV Controlled Sites. For BMV Controlled Sites, the proposer should calculate and enter the personnel costs the proposer expects to pay if awarded a contract and only those site preparation and rental costs specified in the separate Agency Specifications for that location.

1.15 SELECTION PROCESS

General. The Director of the Department of Public Safety and Registrar of Motor Vehicles are dedicated to the purpose of finding deputy registrars who, in their opinions, will serve the needs of the State and the citizens of Ohio, without regard to political affiliation or political contributions. To do this, the Registrar and the Director intend to use this proposal process to find individuals, county auditors, eligible clerks of courts, and nonprofit corporations that meet the requirements as established by the Registrar. From this pool of candidates, the final selection will be made.

The Registrar and Director reserve the right to require additional information from any proposer during the RFP process. The information may be required in written or oral form and may include interviews, presentations, or other media.

Request for proposals. Deputy registrar fees for services to be rendered are set by law. Therefore, this RFP is not one involving bid requirements. Accordingly, the Registrar and Director intend to look at all the relevant factors and make their own decision as to which individuals, nonprofit corporations, county auditors, and clerks of courts will best meet the needs of the State of Ohio and the citizens of Ohio. The Registrar does not intend to contract with anyone who will be disqualified under the terms of ORC [4503.03\(B\)](#) or other applicable statutes. All others will be considered if they propose and meet the mandatory minimum requirements.

Requirements for proposal submission. Proposers wishing to be considered for the deputy registrar agency outlined in this RFP will be required to submit their proposals on the forms prescribed by the Registrar. Each proposal shall be complete and shall be transmitted electronically via email to DeputyRegistrarRFP@dps.ohio.gov. Each proposal shall consist of one complete set of all required documents. Each submission shall be typewritten, computer printed, or legibly hand printed in ink and shall have original signatures (manual or electronic) wherever required. Completed forms should then be saved, scanned, and/or uploaded and transmitted electronically as a PDF (Portable Document Format) attachment via email to DeputyRegistrarRFP@dps.ohio.gov.

Maximum email capacity is 20 MB, and submissions exceeding 20MB must be transmitted via multiple emails. An acknowledgment receipt of submission(s) will be sent to the proposer within 48 hours.

Where notarization is required, submissions should contain all of the following: the original signature (manual or electronic) of the person signing the document, the date of notarization, the notary public's signature, the notary public's printed (or stamped) name, the expiration date of the notary public's commission, and the notary public's official seal. If you are submitting more than one proposal, see the instructions for "Multiple Proposals," listed on page 1-20.

***For raised notary seals, please shade over with a pencil to make distinguishable in electronic format.**

Forms. Deputy Registrar RFP supporting forms may be obtained by downloading them from the BMV Website directly at <http://www.bmv.ohio.gov/dr-rfp.aspx>.

Acceptable documents. Proposers shall submit forms without alteration from the BMV Website, <http://www.bmv.ohio.gov> (listed under "Deputy Registrar Business Opportunity") or access them directly from the 2026 Deputy Registrar RFP page at: <http://www.bmv.ohio.gov/dr-rfp.aspx>.

Unacceptable documents. Computer-generated forms from any source other than the BMV and other non-BMV forms are not acceptable. Forms, attachments, and other documents which do not conform to the requirements of this RFP, which are non-responsive to it, which contain political endorsements, or which contain other improper information may be removed from the proposal and shall not be considered in the evaluation or final selection process.

Submission. Each proposal shall be submitted, via email and in accordance with instructions listed in this document, to DeputyRegistrarRFP@dps.ohio.gov.

Limitation of number of proposals. No proposer shall submit more than two proposals for any Deputy Provided Site location nor more than one proposal for any BMV Controlled Site location. No person shall submit proposals for more than six different locations. The Registrar and the Director may, in their sole discretion, eliminate from any further consideration any proposals that violate this provision.

Multiple proposals. A person submitting proposals for more than one location or site shall submit the following:

All Personal Information and related forms consisting of only one complete original, no matter how many proposals are submitted (this includes the Personal Questionnaire, the WebCheck receipt, local law enforcement report, and credit report). The "Personal" information will be the same for each separate location proposal submission;

The Operational Information and related forms for each location. One complete original for **EACH LOCATION** (whether BMV Controlled Site or Deputy Provided Site). Each individual (different for each location) "Operational" packet will include the same "Personal" information for each proposal submitted;

The Site Information and related forms for each Deputy Provided Site. One complete original for **EACH DEPUTY PROVIDED SITE** proposed; but no information for BMV Controlled Sites.

Example: If submitting proposals for three locations comprised of two Deputy Provided Sites (25-X and 25-Y) and one BMV Controlled Site (25-Z) the PDF submission would be submitted as follows:

25-X: Personal Forms Packet (same for all three locations), Operational Forms Packet (specific to location 25-X), and Site Forms Packet (specific to location 25-X).

25-Y: Personal Forms Packet (same for all three locations), Operational Forms Packet (specific to location 25-Y), and Site Forms Packet (specific to location 25-Y).

25-Z: Personal Forms Packet (same for all three locations) and Operational Forms Packet (specific to location 25-Z) (BMV Controlled Location, no Site Forms Packet required).

Each proposal (PDF attachment) shall be saved and submitted via email as follows:

Proposer Name, Location, Packet Type (Personal, Operational, or Site)

Example using the three locations referenced above:

- **John Smith, 25-X, 25-Y, 25-Z, Personal Forms Packet (same for all locations)**
- **John Smith, 25-X, Operational Forms Packet and Site Forms Packet**
- **John Smith, 25-Y Operational Forms Packet and Site Forms Packet**
- **John Smith, 25-Z Operational Forms Packet**
 - **BMV Controlled location, no Site Forms Packet required**

There would be four separate attachments:

- One Personal Information Packet which will be used for all three locations
- One Operational Forms Packet and Site Forms Packet for location 25-X
- One Operational Forms Packet and Site Forms Packet for location 25-Y
- One Operational Forms Packet for location 25-Z
 - BMV Controlled location, no Site Forms Packet required

Previous proposals not incorporated. If a proposer has previously filed a copy of any required document with the BMV, that proposer is still required to submit a new original of the document as part of this proposal. No credit is given for documents submitted during an earlier proposal process.

Deadlines. Complete proposals must be received by the BMV prior to the deadline set forth in the **RFP SCHEDULE**. "Received" as used in this paragraph means actually received by email prior to the determined deadline.

Scoring systems. In the process of making the final determination, scoring systems and other aids will be employed. Scoring systems are not intended to replace the duty of the Registrar and the Director to exercise discretion in awarding contracts. The Registrar and Director will be guided by the terms of ORC [4503.03](#) and other applicable statutes and administrative rules in making their decisions.

Evaluation. Each proposal received timely will be assigned a proposal number. Any proposal that is incomplete or that contains unacceptable items of any nature may be summarily disqualified. BMV evaluation teams will review and apply individual point value scores to the personal and operational portions of each proposal. For Deputy Provided Sites, an additional Site Evaluation may be performed if determined to be necessary based on the evaluation score results compiled

for the Personal and Operational portions of the proposals. For the purposes of this RFP, primary emphasis is placed on the quality and overall scoring of the Personal and Operational evaluations. The locations proposed for Deputy Provided Sites will be evaluated and scored only in the event of the need to make contract selections based on the quality of the sites proposed with all other factors being comparable. If Site Evaluations are performed, the site proposals will be evaluated by BMV employees. Site Evaluations would be used as an additional aid to assist the Registrar and Director in exercising their discretion as to which proposer will, in their opinion, best serve the needs of the State and citizens of Ohio.

Review by proposers. After all the evaluations and scores have been completed, and before the Registrar and Director perform a final review of the proposals, each proposer shall have an opportunity to review his or her own proposal and any other proposal, and the preliminary scores assigned by the evaluation teams. BMV staff reserve the right to prioritize and process requests to review proposals, requests to obtain copies of proposals, and requests for copies of evaluation scores based on the relevancy to the proposers and their competitors for locations where they have applied. All other requests will be processed as time permits.

Copies of proposals. You may request a copy of any proposal or part thereof by email only.

Copies of proposals submitted under this RFP will be made available for review only after the preliminary evaluation scores have been posted on the BMV Website. Copies of the proposals will be provided free of charge, if requested, and sent via email.

For more information, phone the BMV at (614)752-2090 or send an email to DeputyRegistrarRFP@dps.ohio.gov.

Please include the following information when ordering proposals:

1. Provide us with your name, a telephone number where you can be reached, and a valid/verified email address;
2. Supply the County, City, Location Number, and Proposer Name (if known);
3. Multiple emails may be necessary depending on the file size of the request.

Written Response and Comments. Any proposer may submit a Written Response and Comments to the scores announced in the preliminary evaluation. Any Written Response and Comments shall be submitted on the forms provided by the BMV at the time of the notification of the scores and submitted electronically **via email, identical to RFP proposal submissions.**

Purpose of Written Response and Comments. The purpose of the Written Response and Comments shall be to draw the Registrar's and Director's attention to any alleged errors or discrepancies resulting from the scores received in the preliminary evaluation scoring process. The Written Response and Comments are also the only authorized means to identify and request reinstatement of point(s) not originally granted because of minor clerical or typographical errors or inadvertent errors or omissions. The Registrar and Director reserve the discretion to determine whether a score adjustment is warranted.

Submission of Written Response and Comments. The filing of a Written Response and Comments is optional. However, if a proposer wishes to file, the Written Response and Comments must be received via email (DeputyRegistrarRFP@dps.ohio.gov) by the BMV prior to the deadline set forth in the **RFP SCHEDULE.**

Limitation of communications. BMV employees shall not discuss the scores or answer any questions during the process except through the RFP email inquiry system described below. Any communication or purported communication about the RFP process during the process is prohibited and subject to disciplinary action or proposer disqualification by the Registrar.

RFP email inquiry system. The BMV will establish and maintain an RFP email inquiry system throughout the entire proposal process. All questions regarding the proposal process must be directed through the RFP email inquiry system. The address for the RFP email inquiry system is: DeputyRegistrarRFP@dps.ohio.gov. The questions will be answered and posted on the BMV Website by the end of the next business day (5:00 p.m.) after the question is received. The answers may be viewed by going to the following Uniform Resource Locator (URL) address on the BMV website: <http://bmv.ohio.gov/dr-rfp-email-inquiries.aspx>. This is the only authorized method for making inquiries regarding the deputy registrar proposal process. All answers to any questions and inquiries will be available to all proposers equally. Employees of the Department of Public Safety are not authorized or permitted to amend or modify this RFP nor to give any information about the RFP except at the Proposal Conference (if applicable) or over the RFP email inquiry system, and any attempt to do so is void.

Consideration of proposals. The Registrar and the Director reserve the right to reject any and all proposals and to seek new proposals if such procedure would, in their opinion, best serve the needs of the State of Ohio and its citizens. In addition to all factors mentioned in the RFP, the contract, the appendices, the questionnaires, the forms, the attachments, the definitions, the ORC, the OAC, the Deputy Registrar Manual, and any other directives prescribed by the Registrar, the Registrar and Director reserve the right to consider all relevant factors that impinge upon the best interests of the people and the State of Ohio.

Clarification of proposals. The Registrar and the Director, in their sole discretion, reserve the right to seek clarification of any proposal from any proposer. The Registrar and the Director may consider any information they receive in the clarification process for the purposes of making their final decision. The Registrar and the Director may extend an opportunity to cure scrivener's errors (minor clerical, typographical errors or the unintentional addition or omission of a word, phrase, or figure) depending on the context in which the error(s) or omission(s) occur.

Disqualification. Any proposal which fails to meet the minimum requirements may be disqualified.

Any proposal(s) received after the proposal deadline indicated in the **RFP SCHEDULE** will be disqualified and not considered for any license agency contract opportunities. Any proposal received even one minute late will not be considered.

Any proposal submitted to the BMV, not containing the minimum requirements for evaluation, may be disqualified and not considered for any available license agency contract opportunities.

Selection. The Registrar and Director will make a final selection in accordance with OAC [4501:1-6-02\(Q\)](#). After the Registrar and Director have made their determination to award a contract to the apparently successful proposer, written notification will be sent on the date indicated in the **RFP SCHEDULE**.

Beginning operations. The successful deputy registrar proposer will be expected to begin operations promptly on the beginning date of the contract as set forth in the **RFP SCHEDULE**.

Supplements and amendments to RFP. Notwithstanding any other provisions of this RFP, the Registrar, with the approval of the Director, may supplement or amend this RFP by issuing the supplement or amendment in writing.

1.16 MINORITY BUSINESS ENTERPRISE (MBE) CERTIFIED PROPOSERS

The Director and Registrar will perform a final review of the proposals, taking into consideration all proposals submitted by individuals certified as owners of a minority business enterprise (MBE). (See below for certification information)

Contracts will be awarded to the individual, nonprofit corporation, county auditor, or eligible clerk of court who submitted the best proposal.

In order to qualify as an owner of a minority business enterprise, a proposer must, in his or her own individual capacity, be certified, or become certified, by:

**The Ohio Department of Administrative Services (DAS)
Equal Opportunity Division (EOD)
4200 Surface Road
Columbus, Ohio 43228
Telephone: 614-466-8380**

**You may apply for certification online at:
<http://das.ohio.gov/Divisions/EqualOpportunity/MBEEDGECertification.aspx>**

Application for certification must be submitted to DAS/EOD by the deadline for submission of proposals (see RFP SCHEDULE). The Registrar and the Director will rely on the DAS/EOD certification list to determine whether any proposer qualifies as the owner of an MBE.

In order to qualify for MBE owner certification, the proposer must:

1. Be a citizen of the United States;
2. Be a resident of the State of Ohio;
3. Be a member of an economically disadvantaged group, including:
 - Blacks or African-Americans;
 - American Indians;
 - Hispanics or Latinos;
 - Asians.

4. Be the sole owner or significant owner of a business operated as a proprietorship, partnership, corporation, or joint venture of any kind provided that at least fifty-one percent of the ownership and control is in the hands of members of economically disadvantaged groups;
5. Have owned and operated the business for at least one year.

Minority Business Enterprise (MBE) means an individual, partnership, corporation or joint venture of any kind that is owned and controlled by U. S. Citizens and residents of Ohio, who are and have held themselves out as members of the following socially and economically disadvantaged groups: Blacks or African-Americans, American Indians, Hispanics or Latinos and Asians. To be eligible for MBE certification, the business must be a for-profit business entity. The company must have been in business at least one year prior to applying for certification as a minority business enterprise. The business must be at least fifty-one percent owned and controlled by one or more person(s) belonging to the above-defined economically disadvantaged groups for one year prior to applying for certification. The person(s) claiming eligibility must possess requisite knowledge of the business and industry in which he/she is applying. The person(s) claiming eligibility must have day-to-day control over the business and must exercise final authority over all aspects of the daily operation of the business including, but not limited to operations, financial, business management, human resources and policy decisions. In addition to the requirements for MBE certification, any applicant desiring to bid on a contract awarded by any agency other than the Department of Administrative Services must meet any pre-qualification requirements of that agency.

If the Department of Administrative Services, Equal Opportunity Division determines that the applicant meets the criteria to be certified as an MBE, the applicant will be issued a certificate in recognition of its status. Status as a minority business enterprise is subject to the continuing compliance of the business with MBE rules and regulations, and to review, at any time, by the equal employment opportunity coordinator. The MBE certification will be granted for a period not to exceed two years. The applicant shall be required to revise the application and information provided to the equal employment opportunity coordinator bi-annually. Such revisions shall also contain a yearly financial statement, all pertinent financial records and other financial documents as requested. At the time of recertification, a recertification affidavit, along with the business federal tax return, shall be required. Recertification may include an on-site review at which time the MBE will be required to submit various statements including, but not limited to: capability/eligibility statements and financial statements to ensure continued program eligibility.

Any change in the business structure of the enterprise, the ownership and control of the enterprise, or the type of business conducted by a certified minority business enterprise, shall require a reapplication for certification and a review by the equal employment opportunity coordinator. For more information about the MBE/EDGE Certification Unit, visit the Ohio Department of Administrative Services Equal Opportunity area on the website at: <http://das.ohio.gov/Divisions/EqualOpportunity.aspx>

1.17 TIMELINES AND DEADLINES

Timelines and deadlines will be in effect in accordance with the **RFP SCHEDULE**.

1.18 SUBMISSION REQUIREMENTS

As a convenience to the proposer, below is a list of items that need to be submitted along with your proposal. This list may not be all-inclusive.

All proposal documents shall be submitted electronically via email to DeputyRegistrarRFP@dps.ohio.gov. Only forms downloaded from the BMV Website may be used.

Each proposer shall submit **one original set** of the following (**ONLY ONE PERSONAL FORMS PACKET NEEDS SUBMITTED, EVEN IF PROPOSING MORE THAN ONE LOCATION**):

1. Form **3.0, Personal Checklist**. There are separate columns for individuals, nonprofit corporations, and county auditors or clerks of courts. Using the Checklist will assist you in submitting a complete proposal.
2. Form **3.1, Personal Questionnaire**. Individuals, county auditors, and clerks of court answer for themselves. Nonprofit corporations answer for the nonprofit corporation, not for individual members or employees.
3. Form **3.2, Business and Employment Experience (must include professional resume)**.
4. Form **3.3, Customer Service Experience Question(s)**.
5. Form **3.4, Start-Up Cost Funds on Deposit**.
6. Form **3.5, Political Contributions Report**, (Need not be submitted by county auditors or clerks of court) Nonprofit corporations must submit two forms, one for the nonprofit corporation itself and one for its CEO.
7. Form **3.6, Personnel Policy (only upon request)**.
8. **Comprehensive Written Personnel Policy, submitted electronically, must be provided upon request.**
9. Form **3.7, Security Plan (only upon request)**.
10. Form **3.8, Facility Maintenance Plan (only upon request)**.
11. Form **3.9, Involved and Invested in Your Business**.
12. (A) For **individuals**:
 - i) 2026 personal credit report.
 - ii) 2026 local law enforcement arrest and conviction report.
 - iii) 2026 WebCheck receipt for BCI and FBI criminal background reports.
 - iv) Pre-approval statement for \$25,000 bond from a reputable and verifiable bonding or insurance company.
 - v) Form 3.10(A), Affidavit of Individual.

1.18 SUBMISSION REQUIREMENTS (Cont'd)

(B) For county auditors or clerks of court:

- i) 2026 local law enforcement arrest and conviction report.
- ii) 2026 WebCheck receipt for BCI and FBI criminal background reports.
- iii) Copy of existing bond or CORSA coverage
- iv) Form 3.10(B), Affidavit of County Auditor or Clerk of Courts.

(C) For nonprofit corporations:

- i) Articles of Incorporation.
- ii) 2026 Certificate of Good Standing issued by the Ohio Secretary of State.
- iii) Pre-approval statement for \$25,000 bond from a reputable and verifiable bonding or insurance company.
- iv) Form 3.10(C), Affidavit of Nonprofit Corporation.

Each proposer shall submit **one original set** of the following forms **FOR EVERY SITE PROPOSED**:

13. Form 4.0, Operational Checklist.
14. Form 4.1, Appointment of Agency Managers.
15. Form 4.2, Experienced Employees Summary.
16. Form 4.3, Staffing and Personnel Costs Calculation.
17. Form 4.4, Start-Up Costs Calculation.
18. Form 4.5, Deputy Registrar Contract, completely filled out, signed by the proposer and properly notarized. It is sufficient to submit only the two main contract pages. The terms and conditions pages need not be submitted with the RFP.

FOR EACH DEPUTY PROVIDED SITE PROPOSED, submit one complete original of the following forms which are issued as a separate package (Do not submit these forms for any BMV Controlled Site):

ATTENTION: Proposers applying for contracts at existing license agency locations designated as Deputy Provided Sites, that were previously approved, are required to complete form 5.0 (Deputy Provided Site Checklist), page one (1) of form 5.1 (Site Questionnaire), **and form 5.3 (Lease Option)**. Additional information must be provided if there have been any changes to the site or any other items identified in the Section 5 (5.0 through 5.4) forms, including the Site Plan.

19. For **Deputy Provided Sites only**:

- A. Form 5.0, Deputy Provided Site Checklist.
- B. Form 5.1, Site Questionnaire.
- C. Form 5.2, ADA Checklist.
- D. Form 5.3, Lease Option.
- E. Form 5.4, Proximity Attachment (for "Proximity" sites only).
- F. Site Plan. Submit a complete Site Plan drawing showing all dimensions of the building interior and all areas within the deputy registrar agency.

- G. **Counter Plan.** Submit a complete Counter Plan drawing of all counters showing the complete dimensions of each (even if the counters are already in place). *Copies of previous submissions will be accepted, provided there have not been any changes since the last proposal.*
- H. **Map with the proposed site clearly marked.** Use map provided in Agency Specifications or, if none, provide your own map.

It is important all necessary documents be RECEIVED on time. As stated previously, a receipt email acknowledging successful proposal submission will be sent to the proposer within 48 hours. If receipt email is not received within the specified timeframe, the proposer should follow-up via the provided email (DeputyRegistrarRFP@dps.ohio.gov) to verify successful submission:

END OF REQUEST FOR PROPOSALS. Please see accompanying Appendices and Forms.

STATE OF OHIO
DEPARTMENT OF PUBLIC SAFETY
BUREAU OF MOTOR VEHICLES



CHARLES NORMAN
REGISTRAR

APPENDIX 2.1, ADDITIONAL REQUIREMENTS FOR DEPUTY PROVIDED SITES

Applicability. This Appendix 2.1 and the forms in Section 5 apply only to those sites where the successful proposer will provide the deputy registrar agency site. Proposers who are proposing for a BMV Controlled Site shall disregard Section 5.

Deputy Provided Sites. Except for locations designated by the Registrar as BMV Controlled Sites, the proposer shall be responsible for locating and providing, by lease or ownership, the facility at which the deputy registrar agency will be operated. The proposer shall include in the proposal a description of the proposed site, including the post office address. The post office address shall include the street address, any suite or room number, any floor number or numbers, the city, state, and zip code.

Site Must be Within Boundaries. The proposed site must be within the boundaries prescribed in the Agency Specifications **or in close proximity to the boundaries. Sites proposed outside of the boundaries but in close proximity will be evaluated as received.** The proposer shall state in the Site Questionnaire, Form 5.1, within the corporate limits of what village or city the site is located, and if not in a city or village, in what township. The statement shall also include the county in which the site is located. The proposer shall indicate the site on the location map provided by the BMV with the separate Agency Specifications, or if none is provided, on a map provided by the proposer.

Any proposer choosing to propose a location outside of designated boundaries must also propose a location within the designated boundaries. All proposed locations, inside and outside of set boundaries, are subject to BMV approval/disapproval.

Lease Continuity Agreement. After the contract is awarded, the deputy registrar is **strongly encouraged** to obtain a fully executed lease continuity agreement (LCA) signed by the deputy registrar, the property owner, and the Registrar. The purpose of the LCA is to give the BMV an opportunity to continue the operation of a deputy registrar agency at the same location in the unlikely event that the deputy registrar does not continue the operation of the agency through the entire term of the deputy registrar contract.

Compliance with the Americans with Disabilities Act (ADA). The ADA of 1990 prohibits discrimination and ensures equal opportunity for persons with disabilities in employment, state and local government services, public accommodations, commercial facilities, and transportation. In July 2010, the ADA regulations were revised. The revised final rules went into effect on March 15, 2011, and were published in the 2011 edition of the Code of Federal Regulations (CFR). To obtain specific information with regard to the ADA standards and requirements, please visit the following websites: <http://www.ada.gov> and http://www.ada.gov/2010ADASTandards_index.htm.

The site must be in full compliance with the ADA as applicable. Upon receipt of a contract, each deputy registrar shall take all necessary actions to come into compliance with all applicable ADA requirements.

Parking Requirements. The site must provide adequate parking for the agency's customers and employees. The minimum parking spaces are set forth in the Agency Specifications. The proposer shall answer the questions in the site questionnaire regarding the number of parking spaces available, and whether the parking is shared with other businesses. The BMV prefers parking which is off-street (in a lot or garage) and free of charge. In addition, preference may be given to parking which is reserved exclusively for deputy registrar customers. There must be parking for persons with disabilities which meets all ADA parking requirements.

APPENDIX 2.1, ADDITIONAL REQUIREMENTS FOR DEPUTY PROVIDED SITES (Cont'd.)

In evaluating the parking, the BMV will consider the distance of the ADA parking spaces and the other parking spaces from the closest public entrance of the proposed agency by the shortest route a person could safely walk or travel by wheelchair.

Heating, Ventilation, and Air-Conditioning (HVAC). The proposer must make provisions for the site to have heating, ventilation, and air conditioning equipment sufficient to keep the location at a reasonable temperature.

Security. The site must have provisions for the safety and security of the agency employees, customers, equipment, and inventory (a Security Plan, Form 3.7, is required).

Facility Maintenance. The deputy registrar shall be responsible for facility maintenance, inside and outside of the premises throughout the term of the contract (a Facility Maintenance Plan, Form 3.8, shall be provided upon request).

Floor Space Specifications. The BMV has established the following requirements for floor space (in square feet) for each Size Class of agency.

SIZE CLASS	Customer Area	Employee Service Area	Employee Private Area	Storage Area	Restroom Area	TOTAL AGENCY MINIMUM FLOOR SPACE (MANDATORY)
1	*	*	*	*	*	*
2	200	230	75	100	*	630
3	300	300	95	110	*	830
4	300	300	95	110	*	830
5	440	370	115	130	*	1,080
6	580	440	135	160	*	1,340
7	730	510	155	200	*	1,620
8	880	580	175	270	*	1,930

* There are no minimum size standards for Class 1 agencies. Restrooms are evaluated on adequacy only, not size.

"Customer Area" is the space designated for the public and defined as all of the area outside the counter and any area in which customers gather to await service and receive service.

"Employee Service Area" is the space designated for terminals, central processing unit (CPU), printers, camera, and vision screener. This space includes the counter itself and the operator and work areas behind the counter. It may include the daily usage storage area.

"Employee Private Area" is space designated for the completion of business-related work (for example, report preparation, clerical filing, typing, mailings, etc.) and for employee breaks and lunches.

APPENDIX 2.1, ADDITIONAL REQUIREMENTS FOR DEPUTY PROVIDED SITES (Cont'd.)

"Storage Area" is space designated for storage of records as well as chargeable and non-chargeable BMV items. It must be located separate from other areas and adequately secured to prevent loss or theft of stored items.

"Restroom Area" is the space designated as an adequate restroom facility. In accordance with the Americans with Disabilities Act (ADA), the BMV requires every deputy provided site to have at least one ADA accessible restroom facility available for use by employees of the license agency and customers, upon request. The deputy registrar proposer must also meet all Ohio Building Code requirements to the extent that they apply to the site.

Floor Space Allocation. The foregoing floor space specifications for individual areas (customer, employee service, employee private, storage, and restroom) are suggested as preferred allocations. A proposer may propose a configuration of these areas which differs from the suggested square footage, provided that there is specific and reasonable provision for each area. Generally, an area which is less than eighty percent (80%) of the suggested amount will not be evaluated favorably. Restroom areas will be evaluated on ADA compliance, adequacy, and cleanliness.

"Total Agency Minimum Floor Space (Mandatory)" means the total space to be used for the operation of the agency (including the customer, employee service, employee private, storage, and employee restroom areas and any other areas to be used) expressed in terms of square feet. This is a mandatory requirement. Any proposed facility which fails to meet the total floor space requirements may be disqualified from consideration. However, the Registrar, with the approval of the Director, may waive this mandatory requirement if there is good cause to do so.

Existing Agency Sites. Proposers applying for contracts at existing license agency locations designated as Deputy Provided Sites that were previously approved, are required to complete form 5.0 (Deputy Provided Site Checklist), page one (1) of form 5.1 (Site Questionnaire), **and form 5.3 (Lease Option) only.** Additional information must be provided if there have been any changes to the site or any other items identified in the Section 5 (5.0 through 5.4) forms, including the Site Plan. If an existing license agency site or any required site elements has changed since the last contract was approved, those changed elements will be reevaluated using standards and methods adopted for use in this current competitive award process.

Counter Specifications. Specifications for the counter for each deputy registrar agency are set forth in Section 2.1, on the following pages. A proposer must choose arrangement A or B and comply precisely with all specifications. Incumbent deputy registrars whose counters met previous specifications are not required to meet the new specifications if their existing counters accommodate or will be modified to accommodate the installation of any new equipment. All other proposers must meet the published counter specifications within this RFP document.

Lease Option or Deed. The proposal shall contain a Lease Option on Form 5.3, exercisable if the proposer receives a deputy registrar contract, for the entire period of the contract. If the proposer is the owner of the real estate premises, the proposer shall provide a copy of the deed showing ownership together with a written statement that it is available for the operation of a deputy registrar agency. The terms of the lease option are mandatory and shall not be modified by the proposer or property owner.

APPENDIX 2.1, ADDITIONAL REQUIREMENTS FOR DEPUTY PROVIDED SITES (Cont'd.)

Freestanding Agency. The entrance for the site shall have direct access to the deputy registrar area; patrons shall not be required to enter or pass through any other business to reach the deputy registrar premises. A deputy registrar agency must normally be a separate store with its own entrance. It should have its own walls and be locked to outsiders when closed. It may not normally share space in another business. The Registrar, with the approval of the Director, may waive this requirement for a particular site or location. If the agency is part of a one-stop shopping arrangement, there may be some shared space and a common entrance with the driver license examination station or a clerk of courts title office.

General Requirements. The proposed site shall provide parking for persons with disabilities; accessibility for persons with disabilities; adequate air conditioning, heating, ventilation, and lighting; adequate customer area; adequate employee service area; adequate employee private area (for office and breaks); adequate storage area; and adequate restroom facilities as appropriate. The site shall be well marked with adequate signs to allow potential patrons easily locate the agency.

Equipment and Premises Costs. The BMV will pay directly for the computer communications line installation if the facility is already equipped with 100 MHz circuit. The successful proposer may be responsible to pay for the cost of upgrading the communication circuit to comply with the 100 MHz standard and other associated costs for the electrical connectivity; must pay the cost of standard telephone lines; the electrical line installation, and all other costs of remodeling. The BMV will move BMV equipment, but the successful proposer will need to have personnel available to move license plates and other inventory to any new site. **The BMV recommends proposers select locations already equipped with 100MHz circuit when proposing new locations.**

Note: As stated above, the site criteria contained in Appendix 2.1 and the forms in Section 5 apply only to sites where the successful proposer will supply the site. Forms 5.0 through 5.4 need not be submitted by any proposer for any BMV Controlled Site. However, all proposers are required to submit Forms 3.0 through 3.10, Forms 4.0 through 4.5, the contract, and all other necessary forms and documents.

APPENDIX 2.1, ADDITIONAL REQUIREMENTS FOR DEPUTY PROVIDED SITES (Cont'd.)

Counter Specifications

Current deputy registrars who propose to continue operations at their present license agency location are not required to make any modifications to their existing counters provided the existing counters meet all previous counter requirements and satisfy current operational needs as determined by BMV Field Services staff.

Proposers who are not currently deputy registrars must agree to provide counters which meet all of the following specifications, unless they have a lease option from the landlord and a written agreement from the current deputy registrar to take over an existing agency, including the counters, if awarded a contract.

All proposers who are not current deputy registrars and do not have both a lease option from the landlord and a written agreement from the current deputy registrar must choose one of the following two arrangements and must comply with all other counter specifications.

A. Operator Sit-down

The top of the equipment support counter shall be no less than 28" and no more than 34" from the floor.

The top of the customer service counter shall be no less than 46" and no more than 48" from the floor.

B. Operator Stand-up

The top of the equipment support counter shall be no less than 37" and no more than 39" from the floor.

The top of the customer service counter shall be no less than 46" and no more than 48" from the floor.

APPENDIX 2.1, ADDITIONAL REQUIREMENTS FOR DEPUTY PROVIDED SITES (Cont'd.)

All counters must meet the following specifications:

1. Each deputy registrar agency must have a counter that is accessible to individuals with disabilities. This counter section must be a minimum of 36" wide, 28" to 34" high and 30" to 36" deep, and have a knee-hole opening of at least 27" high (30" preferred height), 30" wide and 19" deep to provide sufficient knee clearance for people in wheelchairs. At least one terminal service area shall be readily accessible for use by individuals with disabilities. In addition, vision screening must be provided to individuals with disabilities and individuals of short stature. The terminal service area and the vision screening area for individuals with disabilities shall be conveniently located at the same or adjacent locations.
2. Counters must also provide space for the vision screener and driver's license camera and supporting equipment. Both must be set at a reasonable height. The vision screener will require a space at least 18" wide and must be on or adjacent to the accessible counter.
3. The length of the equipment support counter must be at least 60" long for each terminal. The depth of the entire counter must be a minimum of 24" and maximum of 36". Each 60" section must be able to support at least 100 lbs. of equipment.
4. Terminals and keyboard equipment must sit on the equipment support counter. The digital photo workstation hardware shall be placed into an area that is located under the work counter area where the digital photo camera is to be installed. The printer(s) required for driver license and identification card processing may sit on the digital photo workstation counter top if adequate space is available or placed on printer stand(s) that meet the requirements to accommodate the printer(s).
5. In those cases where the counter will also act as a printer stand, an additional space of at least 30" per printer is required. Additional counter space and/or stands may be required to support other BMV-provided printers, scanners, electronic signature and credit card pin pads, and other peripheral devices. Accommodations will need to be made for accessibility and the protection of digital signature and credit card pin pads that are installed at each workstation.
6. Each 60" counter section must have a 3" diameter port cut out at the back of the counter work area to allow cable installation through the counter to the equipment. In addition, ports of the same dimensions must be cut out on any counter supports to allow passage of these cables. Brackets may be installed under counters to support cabling.
7. All computer workstation hardware can be powered from a source of 120 volts AC, through a 20-amp circuit breaker. This circuit is a very common type of power found in stores, offices, and homes. The receptacle required is a standard three-prong outlet. Three wires are required: a 120V source, a neutral and separate ground. The same receptacle requirements apply to the peripherals (i.e. display terminals, printers, and scanners). A four-outlet box is required at each station, mounted under the counter about halfway up. All wiring must meet Ohio and/or local building code requirements.

APPENDIX 2.1, ADDITIONAL REQUIREMENTS FOR DEPUTY PROVIDED SITES (Cont'd.)

8. Multiple duplex receptacles can be attached to a single breaker for terminals and printers as long as the maximum current for the entire circuit does not exceed 15 amps. The power source should be free of other types of equipment such as air conditioners, copiers, electric typewriters, coffeepots, or motors. Power receptacles should be provided within 8 ft. of the thin client, thick client and /or personal computer (PC), and 4 ft. of each peripheral device. Grounding for the workstation hardware and all peripherals should be tied to a common point. If the quality of the power source is suspect, an uninterruptible power supply (UPS) should be seriously considered.
9. Positioning of the workstation hardware should be in an area of minimum traffic. The workstation (thin client, thick client and/or PC) shall be placed at a minimum of 3" off the floor. Cables for the terminals and printers should be positioned in a manner that prevents service people or other individuals from stepping on them. Any cable that is run in a walkway, or conceivably could be stepped on must be protected by an appropriate cable cover or raceway. If the thin client, thick client and/or PC is to be installed in a cavity or well, sufficient space should be allowed for adequate ventilation, 18" on all sides. The system should not be installed near sources of heat or sunlight.

Note: If the existing counters of an incumbent deputy require modification, the proposal should indicate a plan to meet the specifications. Any necessary alterations must be done after the contract award is announced and before the new contract begins.

A. Operator Sit-down

The top surface of the equipment support counter shall be a maximum height of 34" from the floor.

The top of the customer service counter must be a minimum height of 46" and a maximum of 48" from the floor.

Note: It is recommended that a minimum 28" clearance be provided below the counter to accommodate a standard two-drawer file or casework that can be located to the right or left-hand side of the workstation to accommodate right and left-handed users.

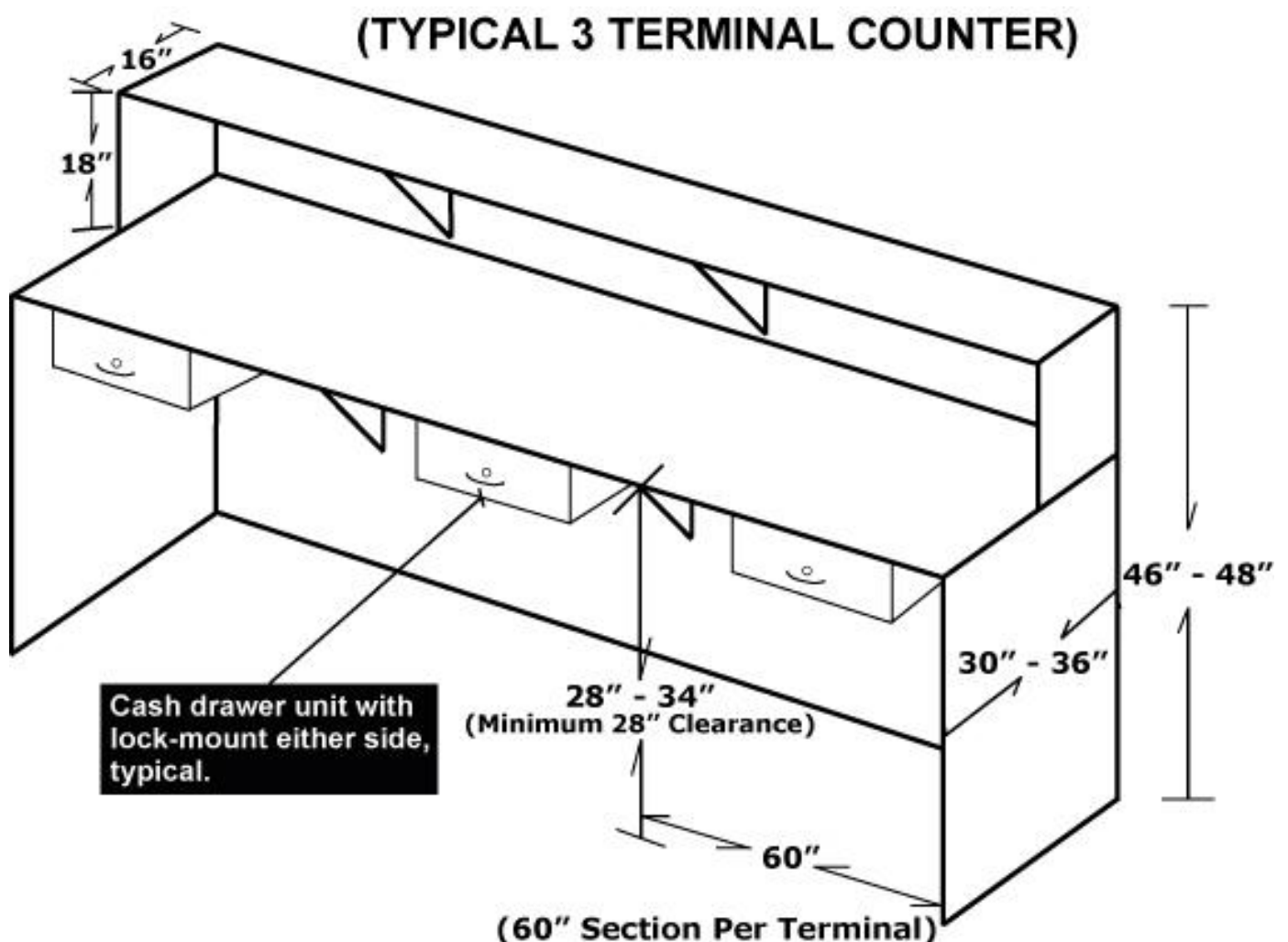

B. Operator Stand-up

The equipment support counter must be a minimum height of 37" and a maximum height of 39" from the floor.

The customer service counter must be a minimum height of 46" and a maximum of 48" from the floor.

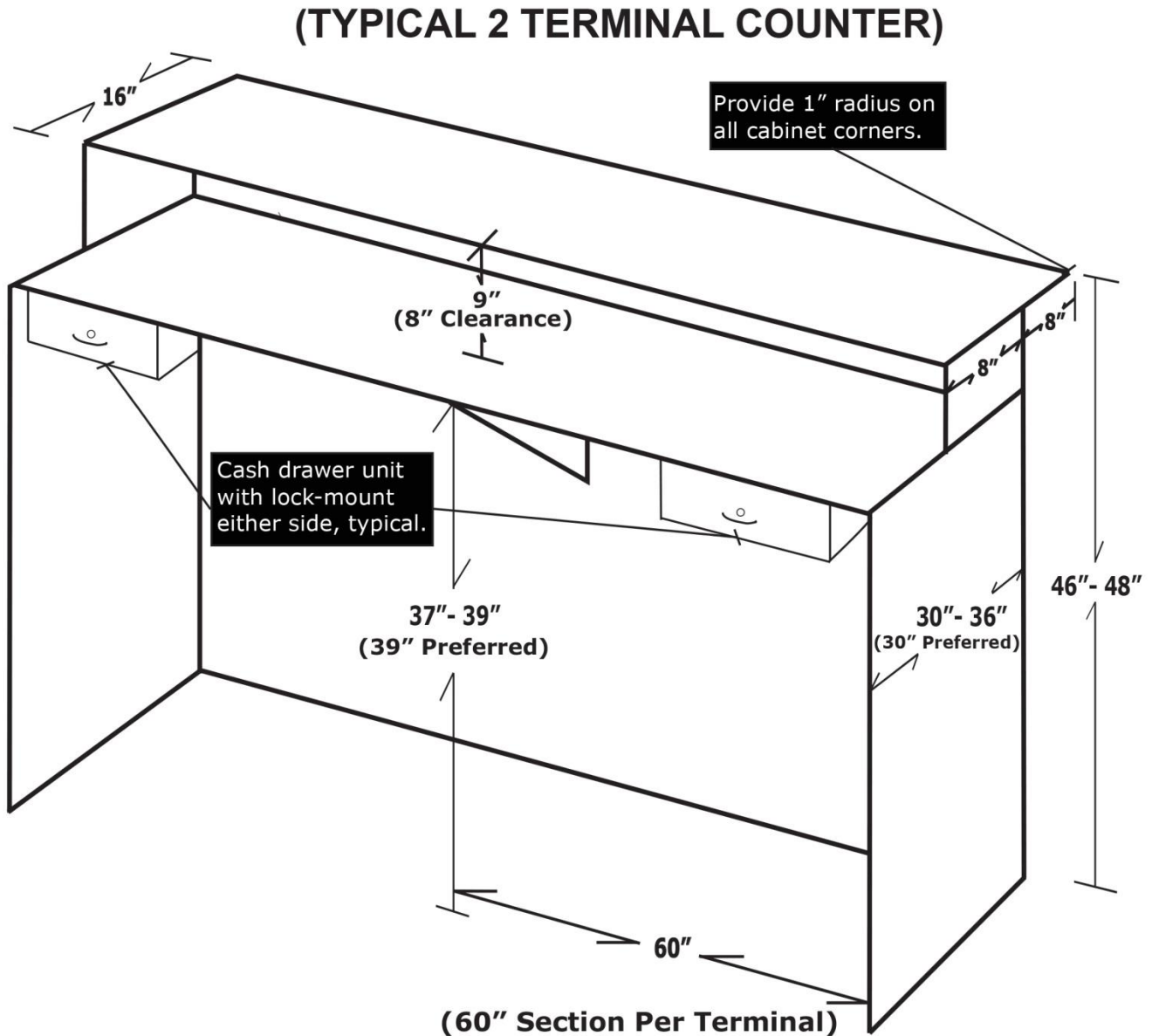

Disability Accessible Counter Requirements and Digital Photo Workstation Counter Recommendations

The drawing below illustrates a counter, which accommodates individuals with disabilities and serves as the digital photo workstation. It must be a minimum of 72" wide (90" width preferred), 30" high (34" maximum height), and 30" to 36" deep. If the vision screener is located on this counter, this counter's width must be 90" to accommodate the 18" space requirement for the vision screener.

The counter used to provide service to individuals with disabilities must have a kneehole opening with at least 27" minimum clearance height, 30" width, and 19" depth. At least one terminal service area shall be readily accessible for use by individuals with disabilities. In addition, vision screening must be provided to individuals with disabilities and individuals of short stature. The terminal service area and the vision screening area for individuals with disabilities shall be conveniently located at the same or adjacent locations.

The workstation counter used to take digital photos for driver licenses and identification cards will accommodate the computer equipment needed to process digital photos and must be located within proximity to where digital camera mount is installed.

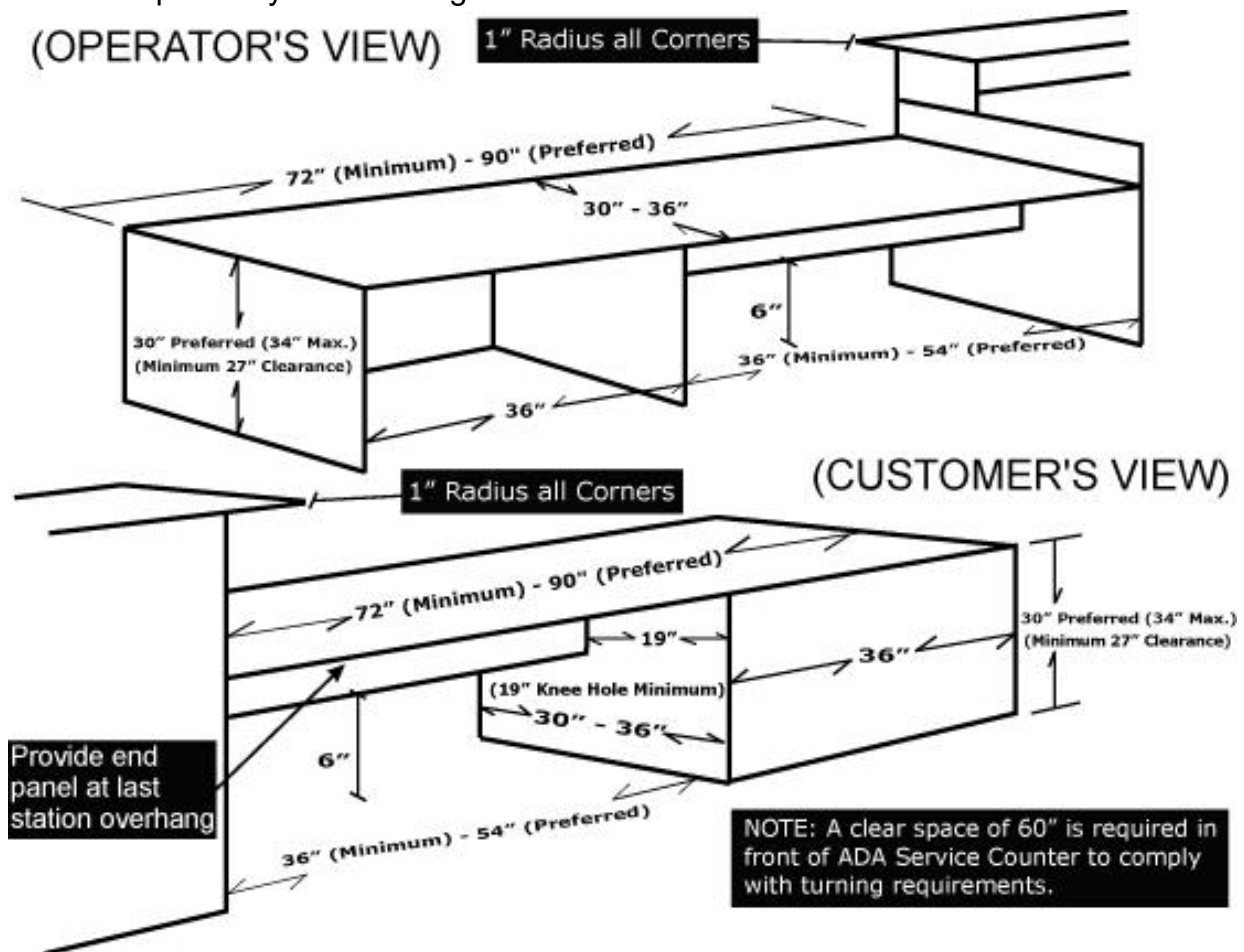

Supplemental Counter Plans

The following counter plans are used by the DPS Facilities Section and include the general specification requirements that are supplied to contractors for building counters at BMV Controlled license agency sites. These specifications include Operator Sit-Down Counter, Operator Stand-Up Counter, Disability Accessible Counter, Rear Counter, Counter Supports Information and General Notes. Additionally, these counter plans are included only as a suggested alternative and are supplemental to the required counter specifications contained on pages 1-10 of Appendix 2.1.

Operator Sit-Down Counter – DPS Facilities Specifications

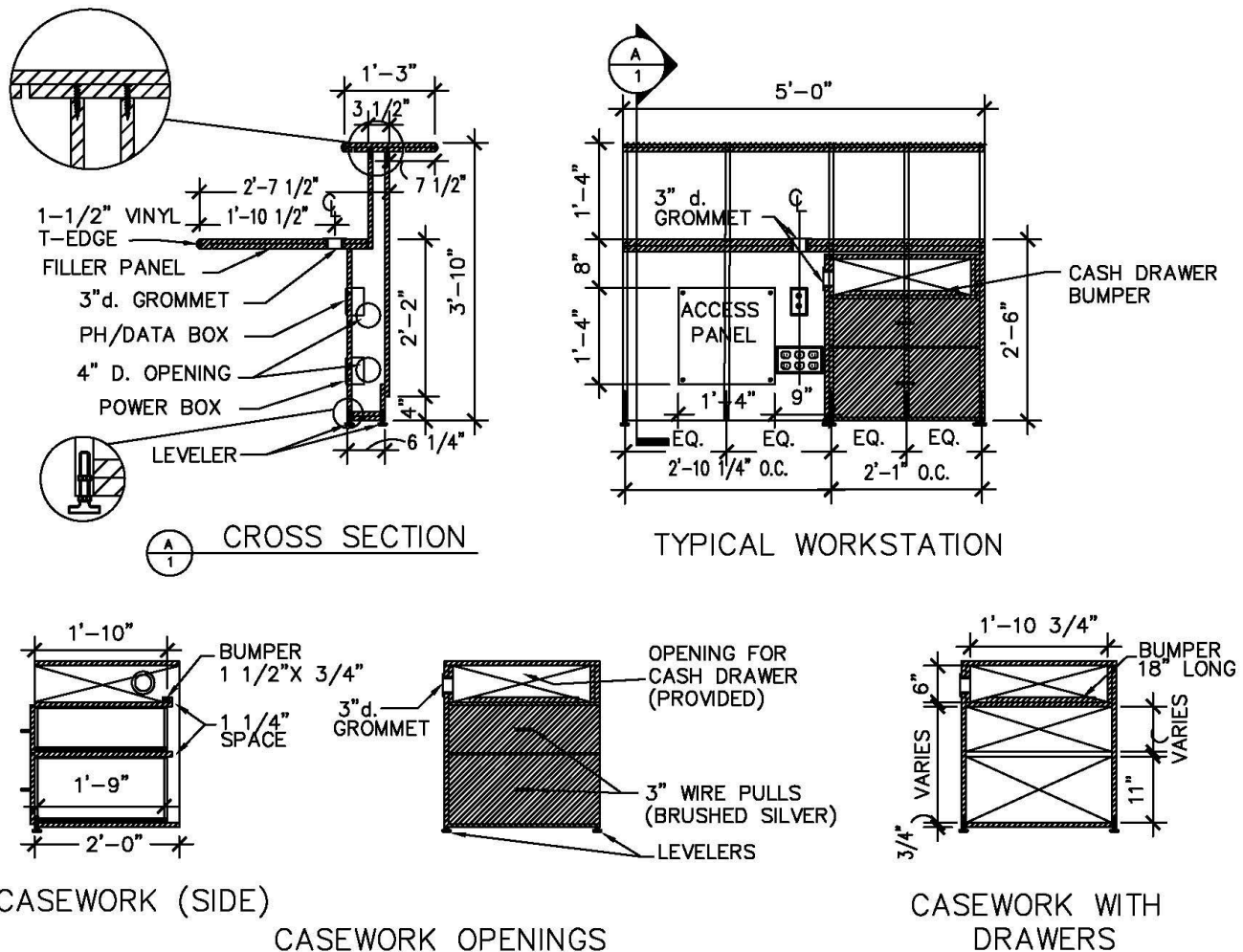

Supplemental Counter Plans (Continued)

Operator Stand-Up Counter – DPS Facilities Specifications

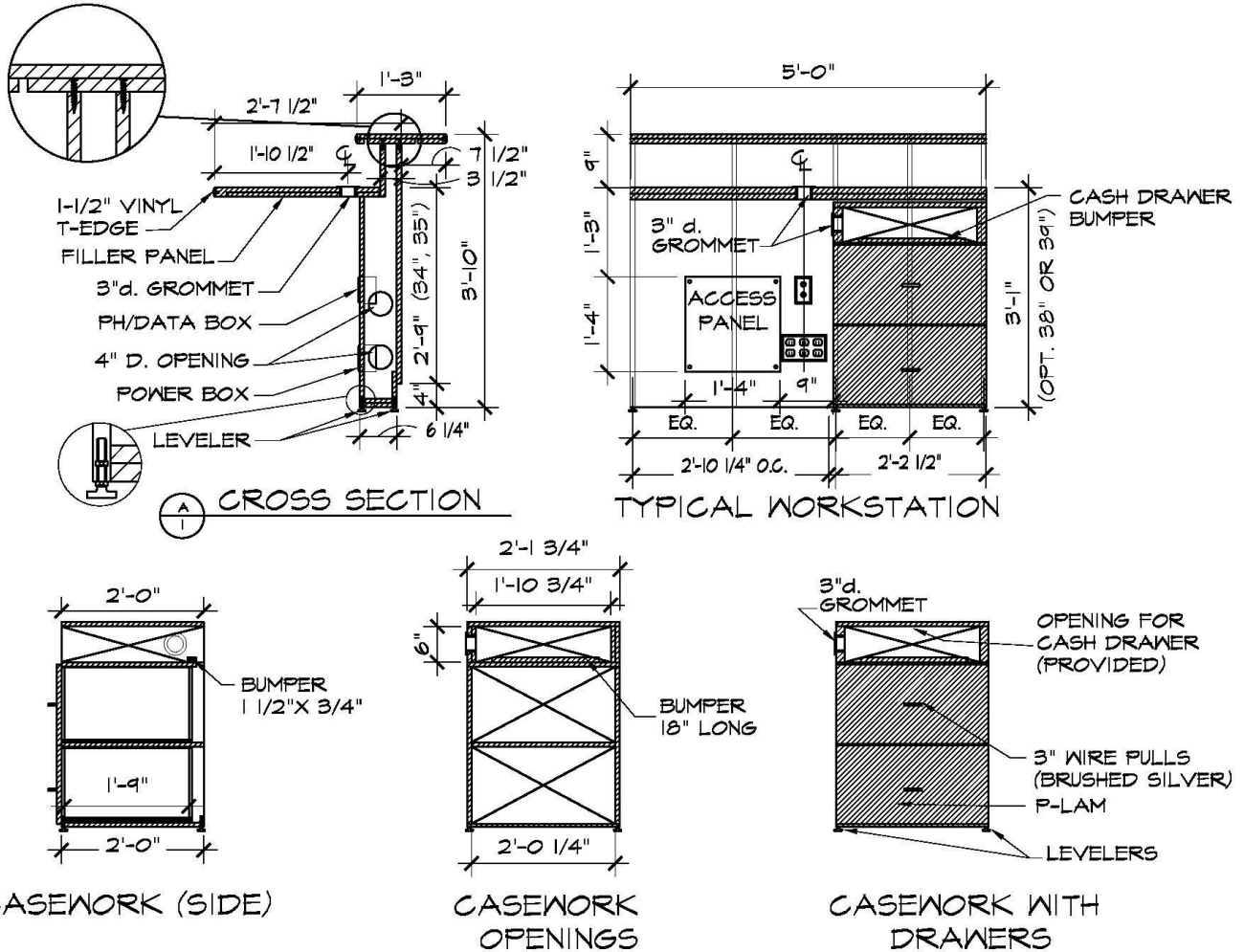

Supplemental Counter Plans (Continued)

Disability Accessible Counter – DPS Facilities Specifications

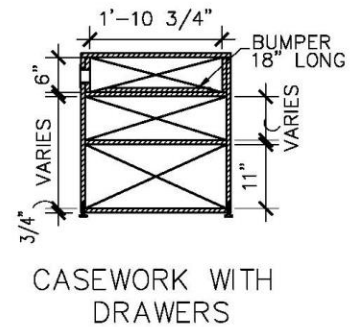
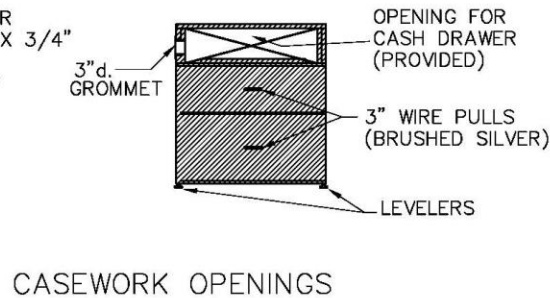
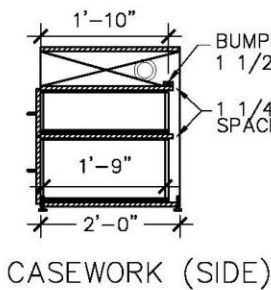
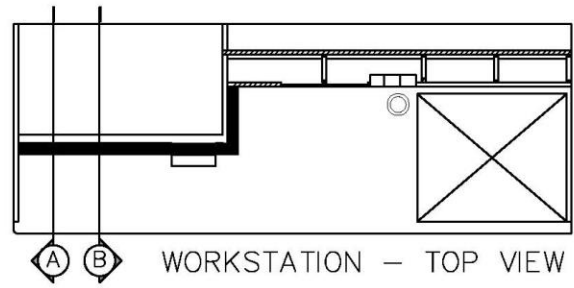
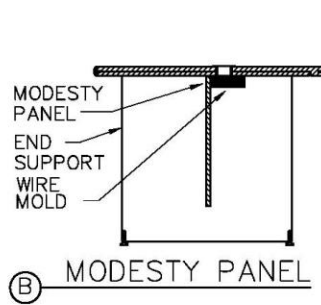
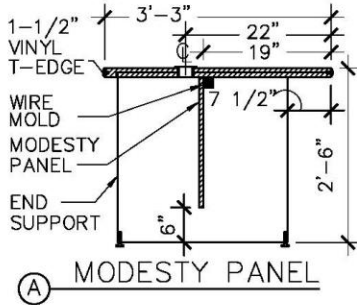
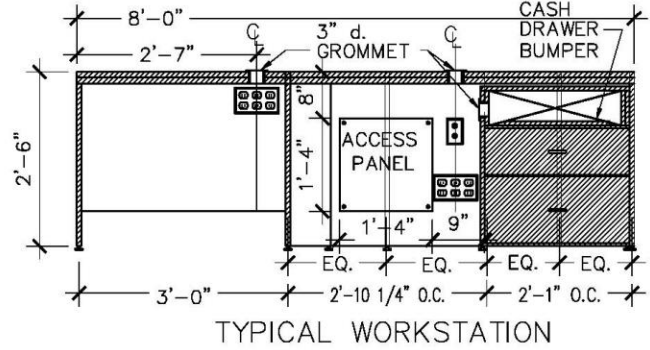
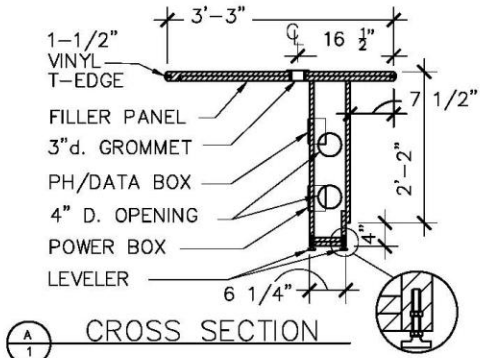

Supplemental Counter Plans (Continued)

Rear Counter – DPS Facilities Specifications

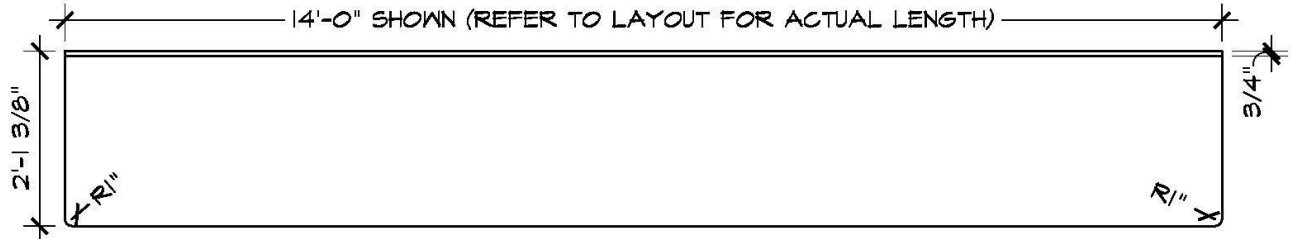

REAR COUNTER - TOP VIEW

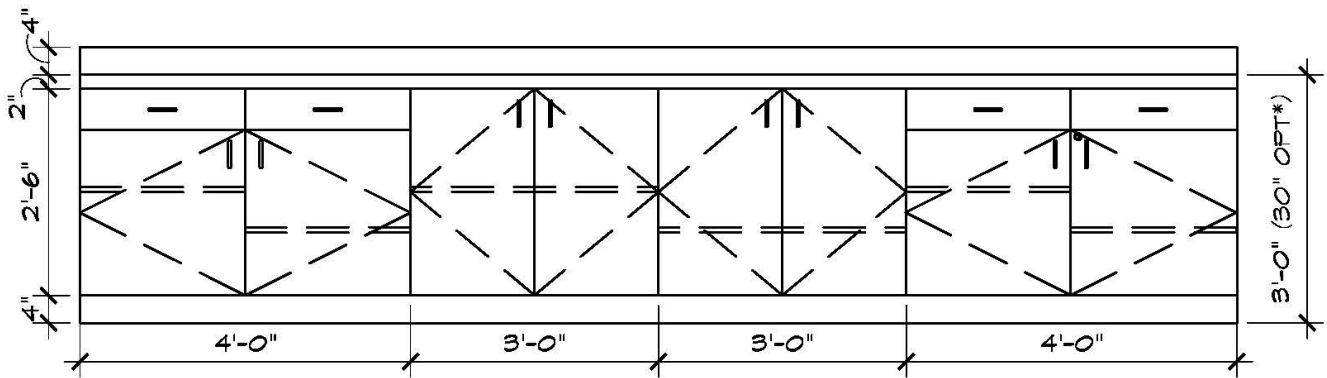

REAR COUNTER - FRONT VIEW

* TYPICAL COUNTER HEIGHT AND CABINET CONFIGURATION SHOWN
ACTUAL CONFIGURATION TO BE DETERMINED BY USER

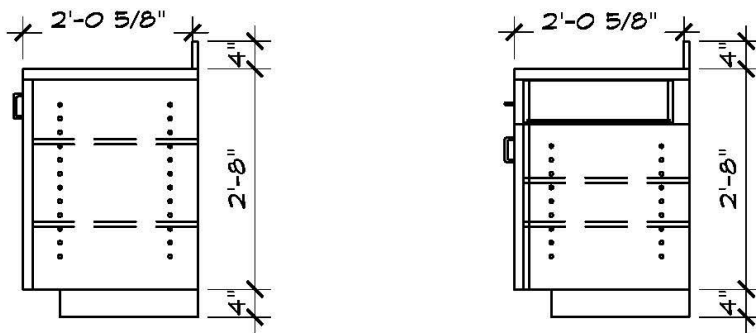

REAR COUNTER - SIDE VIEWS

Supplemental Counter Plans (Continued)

Counter Supports Information and General Notes

GENERAL NOTES:

1. ALL DIMENSIONS TO BE FIELD VERIFIED.
2. PROVIDE SHOP DRAWINGS ON ALL CASEWORK FOR APPROVAL BY OWNER BEFORE FABRICATION.
3. ALL CABINETS AND TOPS TO BE CONSTRUCTED TO MEET ANI "CUSTOM" STANDARDS, EXCEPT WHERE MORE STRINGENT THAN INDICATED.
4. ALL EXPOSED SURFACES SHALL BE LAMINATED EXCEPT WHERE OTHERWISE NOTED.
5. PLASTIC LAMINATE: TO BE DETERMINED
6. COUNTERTOPS: ALL TOPS TO BE CONSTRUCTED FROM 3/4" INDUSTRIAL GRADE 45# DENSITY PARTICLE BOARD W/ BACKER SHEET. (1 1/8" FINISH DIMENSION)
7. RADIUS (1" RAD.) ALL EXPOSED CORNERS
8. PROVIDE PLASTIC T-MOLD ON ALL COUNTER EDGES.
9. FILE DRAWERS: ACCURIDE FULL EXTENSION SLIDES.
10. WIRE PULLS: "HAFELE" # 11639.446 3 1/2" BRUSHED ALUM. FINISH.
11. LEG LEVELERS: "CAMAR" MODEL #450-10-P2.
12. GROMMETS: "DOUG MOCKETT SERIES" WHERE APPLICABLE.
13. CONTRACTOR TO LEVEL ALL COUNTER UNITS UPON INSTALLATION.
14. UPON INSTALLATION, ALL CASE WORK MUST BE CLEANED WITH A PRODUCT (SUCH AS MINERAL SPIRITS) TO REMOVE ALL RESIDUE AND LEAVE A CLEAN APPEARANCE.

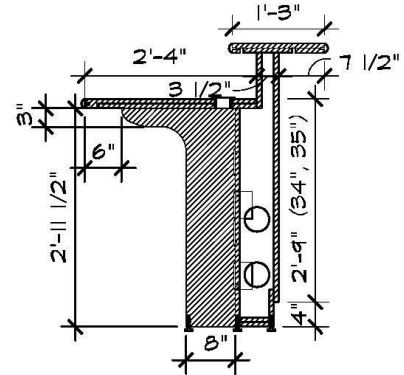
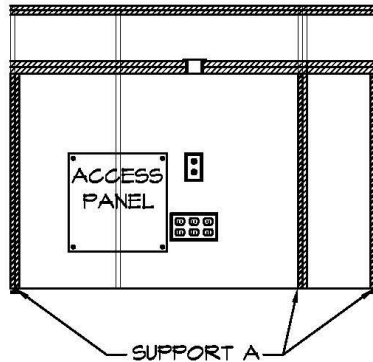

SUPPORT A
(FOR USE WITHIN A WORKSTATION STAND-UP HEIGHT)

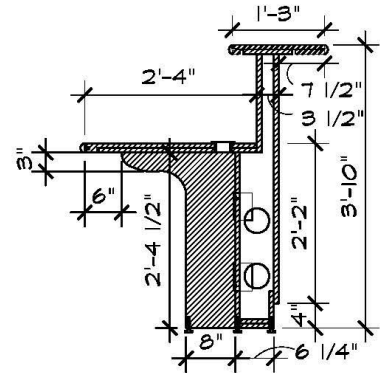

SUPPORT B
(FOR USE WITHIN A WORKSTATION OF SEATED HEIGHT)

APPENDIX 2.2, OHIO ADMINISTRATIVE CODE – RULES

Ohio Administrative Code Rules – Chapter 4501:1-6 Registrars and Deputy Registrars

Source: [LAWriter® Ohio Laws and Rules](http://codes.ohio.gov)
(<http://codes.ohio.gov>)

[Chapter 4501:1-6 Registrars and Deputy Registrars](http://codes.ohio.gov/oac/4501:1-6-01) (<http://codes.ohio.gov/oac/4501:1-6-01>)

[4501:1-6-01 Terms and provisions governing contracts between the registrar and deputy registrars.](http://codes.ohio.gov/oac/4501:1-6-01)
(<http://codes.ohio.gov/oac/4501:1-6-01>)

[4501:1-6-02 Selection and appointment of deputy registrars.](http://codes.ohio.gov/oac/4501:1-6-02) (<http://codes.ohio.gov/oac/4501:1-6-02>)

[4501:1-6-03 Designation of locations and sites of deputy registrar offices.](http://codes.ohio.gov/oac/4501:1-6-03)
(<http://codes.ohio.gov/oac/4501:1-6-03>)

[4501:1-6-04 Limited authority deputy registrars.](http://codes.ohio.gov/oac/4501:1-6-04) (<http://codes.ohio.gov/oac/4501:1-6-04>)

[4501:1-6-05 Deputy registrar authority to collect reinstatement fees.](http://codes.ohio.gov/oac/4501:1-6-05v1) (<http://codes.ohio.gov/oac/4501:1-6-05v1>)

[4501:1-6-06 Deputy registrar vending machines.](http://codes.ohio.gov/oac/4501:1-6-06v1) (<http://codes.ohio.gov/oac/4501:1-6-06v1>)

[4501:1-6-07 Nonprofit corporation deputy registrar proceeds.](http://codes.ohio.gov/oac/4501:1-6-07v1) (<http://codes.ohio.gov/oac/4501:1-6-07v1>)

[4501:1-6-08 Third party advertising at deputy registrar locations.](http://codes.ohio.gov/oac/4501:1-6-08v1) (<http://codes.ohio.gov/oac/4501:1-6-08v1>)

[4501:1-6-09 Multi-year vehicle registration fees.](http://codes.ohio.gov/oac/4501:1-6-09v1) (<http://codes.ohio.gov/oac/4501:1-6-09v1>)

[4501:1-6-10 Vehicle registration convenience fees.](http://codes.ohio.gov/oac/4501:1-6-10v1) (<http://codes.ohio.gov/oac/4501:1-6-10v1>)

[4501:1-6-11 Deputy registrar fees.](http://codes.ohio.gov/oac/4501:1-6-11v1) (<http://codes.ohio.gov/oac/4501:1-6-11v1>)

APPENDIX 2.3, OHIO REVISED CODE – SELECTED LAWS

Ohio Revised Code – Selected Laws

Source: [LAWriter® Ohio Laws and Rules](http://codes.ohio.gov)
(<http://codes.ohio.gov>)

[1702.01 Nonprofit corporation law definitions.](http://codes.ohio.gov/orc/1702.01) (<http://codes.ohio.gov/orc/1702.01>)

[4501.02 Bureau of motor vehicles - division of emergency medical services.](http://codes.ohio.gov/orc/4501.02)
(<http://codes.ohio.gov/orc/4501.02>)

[4501.021 Management of bureau records.](http://codes.ohio.gov/orc/4501.021) (<http://codes.ohio.gov/orc/4501.021>)

[4501.023 Registrar and deputy registrars - voter registration duties.](http://codes.ohio.gov/orc/4501.023) (<http://codes.ohio.gov/orc/4501.023>)

[4501.27 Confidentiality.](http://codes.ohio.gov/orc/4501.27) (<http://codes.ohio.gov/orc/4501.27>)

[4503.03 Deputy registrars.](http://codes.ohio.gov/orc/4503.03) (<http://codes.ohio.gov/orc/4503.03>)

[4503.031 Office space for carrying out deputy registrars' duties.](http://codes.ohio.gov/orc/4503.031) (<http://codes.ohio.gov/orc/4503.031>)

[4503.032 Political contributions.](http://codes.ohio.gov/orc/4503.032) (<http://codes.ohio.gov/orc/4503.032>)

[4503.033 Deputy registrar to file annual statement - contents of statement.](http://codes.ohio.gov/orc/4503.033)
(<http://codes.ohio.gov/orc/4503.033>)

[4503.036 Limited authority deputy registrars.](http://codes.ohio.gov/orc/4503.036) (<http://codes.ohio.gov/orc/4503.036>)

[4503.037 Allocation of motor vehicle-related duties between county auditor and clerk of court of common pleas.](http://codes.ohio.gov/orc/4503.037) (<http://codes.ohio.gov/orc/4503.037>)

[4503.10 Application for registration or renewal - transmission of fees - inspection certificates.](http://codes.ohio.gov/orc/4503.10)
(<http://codes.ohio.gov/orc/4503.10>)

[4507.01 *\[Effective Until 1/1/2019\]* Driver's license law definitions - authority of registrar - deputy registrars.](http://codes.ohio.gov/orc/4507.01) (<http://codes.ohio.gov/orc/4507.01>)

[4507.01 *\[Effective 1/1/2019\]* Driver's license law definitions - authority of registrar - deputy registrars.](http://codes.ohio.gov/orc/4507.01)
(<http://codes.ohio.gov/orc/4507.01>)

[4507.06 *\[Effective Until 1/1/2019\]* Form and content of application for license - registration of electors.](http://codes.ohio.gov/orc/4507.06)
(<http://codes.ohio.gov/orc/4507.06>)

[4507.06 *\[Effective 1/1/2019\]* Form and content of application for license - registration of electors.](http://codes.ohio.gov/orc/4507.06)
(<http://codes.ohio.gov/orc/4507.06>)

[4507.1612 Reinstatement fee before restoration of license.](http://codes.ohio.gov/orc/4507.1612) (<http://codes.ohio.gov/orc/4507.1612>)

[4507.45 Reinstatement fee.](http://codes.ohio.gov/orc/4507.45) (<http://codes.ohio.gov/orc/4507.45>)

APPENDIX 2.4
AGENCY SPECIFICATIONS

LOCATION COUNTY — **Allen**
LOCATION NAME — **Lima**
LOCATION NUMBER — **02-B**

THIS LOCATION:

1. Will have a **contract term** beginning on **June 28, 2026** and ending no later than **June 28, 2031**.
2. Will require **bond coverage** in the amount of **\$25,000.00**.
3. Is designated, and must meet all requirements of, a **Class 3 Agency**.

Annual Transactions	Agency Class Size	Computer Terminals	Recommended Weekly Staff Hrs.	Minimum Parking Spaces	Minimum Sq. Ft.
0-20,000	1	1-2	102	7	—
20,001-35,000	2	1-2	102	7	630
35,001-40,000	3	2-3	107	14	830
40,001-45,000	3	2-3	121	14	830
45,001-50,000	3	2-3	134	14	830
50,001-55,000	4	2-3	147	14	830
55,001-60,000	4	2-3	161	14	830
60,001-65,000	5	3-4	174	21	1,080
65,001-70,000	5	3-4	188	21	1,080
70,001-75,000	5	3-4	201	21	1,080
75,001-80,000	6	4-5	214	28	1,340
80,001-85,000	6	4-5	228	28	1,340
85,001-90,000	6	4-5	241	28	1,340
90,001-95,000	7	5-6	255	35	1,620
95,001-100,000	7	5-6	268	35	1,620
100,001-105,000	7	5-6	281	35	1,620
105,001-110,000	7	5-6	295	35	1,620
110,001-115,000	7	5-6	308	35	1,620
115,001-120,000	7	5-6	322	35	1,620
120,001-125,000	8	6-7	335	42	1,930
125,001-130,000	8	6-7	348	42	1,930
130,001-135,000	8	6-7	362	42	1,930
135,001-140,000	8	6-7	375	42	1,930
140,001-145,000	8	6-7	389	42	1,930
145,001-150,000	8	6-7	402	42	1,930
150,001-155,000	8	6-7	415	42	1,930
155,001-160,000	8	6-7	428	42	1,930
160,001-175,000	8	6-7	441	42	1,930
175,001-190,000	8	6-7	454	42	1,930

4. Is estimated to have generated the following business over the previous twelve months:

TOTAL VEHICLE REGISTRATION TRANSACTION	32,551
TOTAL DRIVER LICENSE/IDENTIFICATION CARD TRANSACTIONS	9,885
PERCENTAGE OF 8-YEAR DL/ID TRANSACTIONS	50%
TOTAL TRANSACTIONS*	44,104
TOTAL PROJECTED ANNUAL REVENUE	\$262,982.90

* Use the “TOTAL TRANSACTIONS” estimates for calculating the agency class size, number of computer terminals, minimum weekly staff hours, minimum parking spaces, and minimum square footage requirement. Please note, other transactions in addition to vehicle registrations and driver license/identification cards make up the “Total Transactions.”

* Percentage of 8-year DL/ID transactions and other transaction information is for calendar year 2023.

Disclaimers: All data listed in this section are estimates based on evaluations of transactions over a recent twelve-month period and may not accurately reflect actual future transactions. All figures may be subject to fluctuation or changes. The number of transactions may vary for many reasons. The number of deputy registrar agencies may increase or decrease. Other competitive factors may affect the number of transactions. Finally, the fees may be affected by changes to the applicable laws.

Therefore, the Registrar makes no representations nor guarantees regarding the accuracy of the estimates, the actual number of transactions which may be expected to occur under the proposed contract, nor the listed fees.

6. Is designated **BMV CONTROLLED SITE**, see BMV Controlled Site Form, included.
- Is designated **DEPUTY PROVIDED SITE, PROXIMITY**, proposers must submit Form 5.4, Proximity Attachment. See DEPUTY PROVIDED SITE ATTACHMENT, included.
- Is designated **DEPUTY PROVIDED SITE, WITHOUT ANY ONE-STOP SHOPPING CONSIDERATIONS**, proposer should not submit Form 5.4 and should **NOT** attempt to make any arrangements in conjunction with a driver license examination station or clerk of courts title office. See DEPUTY PROVIDED SITE ATTACHMENT, included.
7. **GEOGRAPHIC AREA.** The deputy registrar site shall be located within the State of Ohio, County of **Allen** and **within the boundaries of the attached map.**

ALLEN COUNTY

LIMA – LOCATION #02-B

GEOGRAPHIC AREA SHEET



The site chosen for this location shall be in close proximity (evaluated as received) or within the boundaries listed below:

- | | |
|-------------------|---|
| Northern Boundary | – Bluelick Rd. |
| Eastern Boundary | – Thayer Rd. to Bellefontaine Rd. to Hanthorn Rd. |
| Southern Boundary | – Hanthorn Rd. |
| Western Boundary | – St. John’s Ave. to S. Pine St. to E. Elm St. to Calumet Ave. to E. Market St. to N. Sugar St. |

NOTE: If proposing a location OUTSIDE the established boundaries, a location WITHIN the established boundaries must also be proposed. All proposed locations, inside and outside of set boundaries, are subject to BMV approval/disapproval.

APPENDIX 2.5

Table of Contents

2026 Deputy Registrar Contract Terms and Conditions

<u>PROVISION</u>	<u>PAGE</u>
1. GENDER.....	4
2. COMPLIANCE WITH LAWS	4
Compliance requirements	4
3. NATURE OF CONTRACT.....	4
Deputy registrar’s status as an independent contractor	4
Other competitive factors	5
4. FEES TO BE CHARGED; CONSIDERATION	5
5. SERVICES TO BE PERFORMED	5
Anatomical donations and health care instruments	5
Charitable donations	5
Voter registration.....	6
Selective Service information.....	6
Temporary tags.....	6
Correspondence	6
Display of promotional materials	6
BMV initiatives.....	6
6. GEOGRAPHIC AREA	6
Non-exclusive territory.....	6
7. MINIMUM PERSONAL QUALIFICATIONS.....	7
Initial training	7
Financial solvency of Deputy Registrars.....	7
Residency requirements.....	7
Criminal records	8
Other businesses require prior approval	8
Nonprofit corporation in good standing	8
8. POLITICAL CONTRIBUTIONS.....	8
9. DEPUTY REGISTRAR LIABILITY.....	8
Security requirements.....	8
10. INDEMNIFICATION	9
Insurance and hold harmless.....	10
11. BOND REQUIREMENTS.....	10
12. COMPUTERS AND BMV-SUPPLIED EQUIPMENT	10

<u>PROVISION</u>	<u>PAGE</u>
13. INVENTORY	10
14. OFFICE HOURS.....	11
15. OFFICE MANAGEMENT	11
16. EMERGENCIES	11
17. EMPLOYEES	11
Background checks.....	11
Hiring, compensation and discipline	12
Self-reporting of criminal convictions and driver license suspensions by deputy registrars and deputy registrar employees	12
Bilingual employees	12
Personnel policy	12
Employee performance.....	13
Staffing levels	13
Roster of employees	13
Training	13
Equal opportunity	13
Notice of equal opportunity.....	13
Equal opportunity in services	14
Compliance with regulations	14
Nondiscrimination	14
Solicitations for subcontracts, including procurements of materials and equipment	14
Information and reports	15
Sanctions for noncompliance.....	15
Incorporation of provisions	15
Avoidance of sexual harassment	17
Withholding taxes and premiums	17
Federal Insurance Contributions (FICA) tax	17
Workers' Compensation.....	17
Credit disclosure.....	17
18. BANKING REQUIREMENTS	17
Prohibition against commingling.....	18
Acceptance of checks	18
Effect of federal check clearing for the 21 st Century Act.....	18
19. CREDIT AND DEBIT CARDS.....	18
20. TELEPHONE ACCESSIBILITY.....	18
21. RECORD KEEPING	19
Records retention.....	19
22. MINIMUM SITE CRITERIA.....	19
23. LEASE FILING AND LEASE CONTINUATION AGREEMENT.....	19

<u>PROVISION</u>	<u>PAGE</u>
24. BUSINESS ENVIRONMENT	19
25. FACILITY STANDARDS	19
Facility maintenance	20
Counters	20
Office furniture, equipment and supplies	20
Special provision for certain BMV Controlled Sites	20
Signs	20
26. EVALUATION	20
Correction of deficiencies	21
27. LIQUIDATED DAMAGES	21
28. CLOSURE OF AGENCY UPON DEATH OR DISABILITY OF DEPUTY REGISTRAR	21
29. TERMINATION BY DEPUTY REGISTRAR	22
30. TERMINATION BY REGISTRAR	22
31. REMOVAL OF DEPUTY REGISTRAR	22
32. GOOD FAITH	22
33. START OF BUSINESS	22
34. AMENDMENT	22
35. GOVERNING LAW; SEVERABILITY	22
36. NO ASSIGNMENT	22
37. EFFECT OF FEDERAL REAL ID ACT	22
38. ANIMALS ON PREMISES	23
39. NO GIFTS OR TIPS TO BE ACCEPTED	23
40. VENDING SERVICE	23
41. COLLECTION OF REINSTATEMENT FEES	23
42. MINORITY BUSINESS ENTERPRISE CERTIFIED	23
43. ENTIRE CONTRACT	24

APPENDIX 2.6

2026 DEPUTY REGISTRAR CONTRACT TERMS AND CONDITIONS

1. **GENDER.** It is understood by the parties that the deputy registrar may be referred to herein as "he," "she," or "it," or variations thereof, and that those references shall be construed as referring to the person appointed as a deputy registrar herein, whether that person be a natural person of the male gender or the female gender, or a nonprofit corporation.
2. **COMPLIANCE WITH LAWS.** The parties acknowledge and agree that the position of deputy registrar is created by statute and the powers, authority, duties, and limitations set forth in the Ohio Revised Code (ORC) and the Ohio Administrative Code (OAC) are controlling. The deputy registrar agrees to comply with all applicable federal, state, and local laws in the conduct of the deputy registrar agency. The Bureau of Motor Vehicles (BMV) intends to monitor, in particular, each deputy registrar's compliance with the Americans with Disabilities Act (ADA) and the Equal Employment Opportunity (EEO) Act. The deputy registrar shall obtain a vendor's license and shall collect Ohio sales tax when required by law.

Compliance requirements. The deputy registrar agrees to abide by the provisions of the request for proposals (RFP), the proposal, this Contract, the Deputy Registrar Manual, the requirements contained in directives from the BMV, and any other matter reasonably prescribed by the Registrar of Motor Vehicles (Registrar, herein).

3. **NATURE OF THE CONTRACT.** This contract is in the nature of a non-exclusive, limited franchise contract. It is in the nature of a franchise contract because deputy registrars are authorized to perform governmental licensing functions on behalf of the Registrar and the State of Ohio and because deputy registrars are independent contractors and not employees of the State. The franchise is non-exclusive because there is no protected franchise territory and the Registrar may establish additional deputy registrar agencies at any time the Registrar deems it advisable. The franchise is limited because this contract terminates absolutely at the end of the contract term. The ORC may require the deputy registrar to provide certain services without charge. In consideration of the award of this contract, the deputy registrar agrees to provide those specified services without charge.

Deputy registrar's status as an independent contractor. The parties acknowledge and agree that the BMV is an agency of the State of Ohio and that each deputy registrar is an independent contractor. County auditors and clerks of courts holding a deputy registrar contract are public officials of the counties in which they serve. Both they and their employees are employees of their respective counties, which are political subdivisions of the State of Ohio. They are eligible to participate in the Ohio Public Employees Retirement System (OPERS) through their county employment. Individuals holding a deputy registrar contract own and operate their respective deputy registrar agencies as independent contractors. Neither they nor their employees are employees of the State of Ohio or any of its political subdivisions and they are not eligible to participate in the Ohio Public Employees Retirement System. Nonprofit corporations holding deputy registrar contracts own and operate their respective deputy registrar agencies as independent contractors; their employees are not employees of the State of Ohio, nor any of its political subdivisions, and their employees are not eligible to participate in the Ohio Public Employees Retirement System. Upon selection, deputy registrars, other than county auditors and clerks of courts, are required to complete the PEDACKN form (<https://www.opers.org/forms-archive/PEDACKN.pdf>) acknowledging their status as independent contractors.

Other competitive factors. The parties acknowledge that the BMV will continue to offer vehicle registration and other services by mail, over the Internet, and over the telephone through interactive voice recognition systems. The BMV may offer vehicle registration and other services through the use of self-service terminals (SSTs) located throughout Ohio. Pursuant to ORC 4503.036, the BMV has established limited authority deputy registrars (LADRs). LADRs are certain clerks of courts and motor vehicle dealers who are authorized to process motor vehicle registrations at the time they are applying for or processing applications for certificates of title. These activities may affect the number of transactions conducted by deputy registrars. In addition, the BMV may explore alternative methods to issue and provide driver licenses, identification cards, vehicle registrations and other BMV-related services.

4. **FEES TO BE CHARGED; CONSIDERATION.** The deputy registrar shall charge those fees and only those fees, no more and no less, provided in the ORC for statutory services. The deputy registrar shall turn over all amounts as required to the BMV and shall retain the statutory service fees in consideration for services rendered as provided under this contract.
5. **SERVICES TO BE PERFORMED.** The deputy registrar shall perform the duties prescribed for deputy registrars in the ORC, the OAC, the RFP, the proposal, the Deputy Registrar Manual, directives from the Registrar via the Bureau of Motor Vehicles (BMV), and any other requirement prescribed by the Registrar. These duties shall include, but are not limited to: duties related to the issuance of drivers' licenses, commercial drivers' licenses, Ohio identification cards, motorcycle and moped licenses; issuing vehicle registrations; administering motor vehicle inspections; recording the willingness of applicants to make anatomical organ donations; making notations of durable powers of attorney and other health care instruments; conducting vision screening; conducting voter registration; collecting certain charitable donations; providing certain public information; collecting next of kin information; and other services as required by law or directed by the Registrar. Deputy registrars must be able to perform all license agency transactions. In instances where clerks of court, county auditors, or nonprofit corporations are appointed as deputy registrars, the office manager must be able to perform all license agency transactions. BMV field staff will be authorized to conduct periodic testing to verify this proficiency. The parties acknowledge and agree that the duties of deputy registrars and the services to be performed may be changed during the term of this contract as necessary to comply with revised laws, administrative rules, Deputy Registrar Manual, or directives by the Registrar.

Anatomical donations and health care instruments. As required by ORC Section 4507.06, the deputy registrar shall ask each person who is applying for a driver license and identification card whether the applicant wishes to certify willingness to make an anatomical donation and whether the applicant has executed a durable power of attorney for health care or an instrument regarding life-sustaining treatment.

Charitable donations. The deputy registrar may be required to give customers an opportunity to donate, and collect donations, on behalf of certain charitable organizations as provided by statute.

Voter registration. The deputy registrar shall comply with any voter registration rules adopted by the Registrar or the Ohio Secretary of State and shall offer voter registration services as prescribed by the Registrar. Voter registration services shall include new registrations, changes of address, and changes of name. The deputy registrar shall maintain an accurate record of the number of applications from persons eighteen years of age or older for drivers' licenses, permits, renewals, endorsements, or duplicates thereof, the number of voter registrations, changes of address and changes of name processed, and the number of applicants who declined any voter registration services.

Selective Service information. The deputy registrar shall comply with federal and Ohio laws and regulations governing the collection and reporting of Selective Service information.

Temporary tags. The deputy registrar shall not issue any temporary license tag except in strict compliance with the requirements of the ORC and the Registrar.

Correspondence. The deputy registrar shall respond to all correspondence from the BMV within ten calendar days of receipt, or sooner if the circumstances dictate or if specifically requested by the BMV.

Display of promotional materials. The deputy registrar shall display posters and brochures as authorized and directed by the Registrar in prominent locations so as to be readily visible to the public. The deputy registrar shall participate in special projects and promotions when authorized or requested by the Registrar.

The BMV views deputy registrars as a part of the community they serve and as representatives of the state. Deputy Registrars are encouraged to market the community and state within their agency and share ideas on doing so with the BMV.

BMV Initiatives. The deputy registrar shall participate in any/all BMV initiatives as required by the Registrar. This includes but is not limited to technological advancements for improving and streamlining customer service provided at deputy registrar agencies, such as, participation in Get In Line Online (GILO) and QFlow operating systems.

6. **GEOGRAPHICAL AREA.** The deputy registrar shall open and maintain the agency within the location specified and designated in the RFP and at the site approved by the Registrar and the Director of Public Safety (Director, herein). The deputy registrar shall not move the agency to another site without the advance written consent of the Registrar. The deputy registrar shall not open or maintain an office in violation of zoning laws or any other law or regulation or court order.

Non-exclusive territory. The deputy registrar understands that there is no entitlement to an exclusive territory in that the Registrar has full statutory authority under ORC Section 4503.03 to determine the number of deputy registrars within the State of Ohio, including within the immediate area surrounding the site of the deputy registrar and has full statutory authority to appoint whomever the Registrar, with the approval of the Director, wishes, within the restrictions imposed by statute or administrative rule. The Registrar may also appoint limited authority deputy registrars as provided by statute and administrative rule.

7. **MINIMUM PERSONAL QUALIFICATIONS.** The deputy registrar understands and agrees that no person shall operate a deputy registrar agency if he or she is serving in an elective public office either by election or appointment. This limitation does not apply to any county auditor, any clerk of courts in a county having a population of not more than fifty thousand or appointed as deputy registrar under provisions contained in Section 4503.03(A)(1)(c) of the ORC, or any deputy registrar who, subsequent to being awarded a deputy registrar contract, is elected to an office of a political subdivision. An individual deputy registrar may operate more than one deputy registrar agency only with the written permission of the Registrar; a nonprofit corporation formed for the purposes of providing automobile-related services to its members or the public, and a clerk of courts may operate at more than one location in accordance with applicable statutes and administrative rules.

Initial training. Newly appointed deputy registrars shall attend training sessions prescribed by the Registrar prior to the opening of the agency to assure that customer service is effectuated.

Financial solvency of Deputy Registrars. Continuation of each deputy registrar's contract is contingent upon the deputy registrar maintaining fiscal responsibility and financial solvency during the full term of the deputy registrar's contract. The deputy registrar shall comply with license agency financial self-reporting, submission of annual credit reports, undergo routine financial reviews and other requirements specified within the Deputy Registrar Manual. The Registrar shall require each individual deputy registrar (unless otherwise directed by the Registrar, county auditors, clerk of courts and nonprofit corporations will not be required to submit annual credit reports) to make available a complete credit report, including credit score, annually on a date set by the Registrar. Appropriate BMV staff shall review each credit report and shall determine whether additional monitoring by the BMV is warranted to ensure the deputy registrar continues to maintain fiscal responsibility and financial solvency and that BMV funds are adequately protected and promptly deposited in the State of Ohio account. Additionally, the deputy registrar shall make available a (current year) credit report to be reviewed by the Field Advisor or other authorized BMV representative upon request

Residency requirements. Prior to the award of a contract, the person appointed shall give evidence, satisfactory to the Registrar, that he or she is legally entitled to work in the United States of America. Each individual deputy registrar shall occupy a primary residence in a location within the State of Ohio. As used herein, "primary residence" means a residence that meets all of the following: it is the place where the deputy registrar customarily lives; the one place that is the deputy registrar's true, principal, and permanent home; and the place he or she intends to remain. If the deputy registrar is a nonprofit corporation, it shall maintain a place of business within the county in which each of its agencies are located. The Registrar may, upon notice and the deputy registrar's failure to cure the failure to comply with the residency requirement within 30 days of sending that notice, terminate the contract of any deputy registrar who violates this provision.

Criminal records. No person shall be eligible to be a deputy registrar or deputy registrar employee or be able to continue in those capacities if the person has within the previous ten years been convicted of a felony (a crime punishable by death or imprisonment in excess of one year) or any crime involving dishonesty or false statement.

Other businesses require prior approval. The deputy registrar agrees not to operate any other business or sell any other products or services on the deputy registrar premises without the prior written approval of the Registrar.

Nonprofit corporation in good standing. In the case of a deputy registrar that is a nonprofit corporation, the continuation of this contract is contingent upon the deputy registrar maintaining its good standing as a nonprofit corporation with the Ohio Secretary of State. If the corporation loses its good standing, it must report such fact within seventy-two hours to the Registrar.

8. **POLITICAL CONTRIBUTIONS.** A deputy registrar shall comply annually with the provisions of ORC Section 4503.033, which requires deputy registrars to file a disclosure of political contributions annually, no later than January 31st of the year following each calendar year. This contract is contingent upon the deputy registrar's continuing compliance with the provisions of ORC Section 4503.03(B) and 4503.032 with regard to political contributions. If the deputy is a nonprofit corporation, it shall file a disclosure statement for the nonprofit corporation itself and a disclosure statement for its chief executive officer having responsibility for the deputy registrar agency. A county auditor or clerk of a court of common pleas is not required to file the disclosure statement or pay the filing fee required under ORC Section 4503.033.
9. **DEPUTY REGISTRAR LIABILITY.** The deputy registrar shall be required to accomplish routine care of the equipment provided by the BMV, as prescribed by the manufacturer and the Registrar, in order to ensure that it continues in good working order, including but not to be limited to, daily cleaning of equipment and routine inspection for and removal of any debris that may impede or prevent the correct operation of any equipment. The deputy registrar shall be responsible for the cost of repairs to the equipment when damage is due to fault on his or her part or that of his or her employees. The deputy registrar shall ensure that the license agency is free of potential fire and safety hazards at all times. The deputy registrar shall be personally and strictly liable for the consignment value of all license plates, stickers, all other inventory, and state-owned equipment issued by the BMV.

Security requirements. The deputy registrar is responsible for supplying equipment necessary to keep secure all BMV funds, equipment, inventory, and records. At minimum, each deputy registrar shall supply a safe or secure locking cabinet and an acceptable, off-site monitored reporting alarm system. The alarm system shall include a feature which automatically reports off-site if wires are cut or disconnected. The deputy registrar is responsible for assuring that all appropriate items are securely stored and locked and that the agency is secured and locked at all times the agency is not open for business. In addition, the following requirements will be imposed for license agency security:

Security requirements (Cont'd.). (1) installation of a monitored recording video surveillance system to sufficiently observe customer and employee activity inside of the license agency business with a sufficient number of security cameras to fully view all areas of each entrance to include all points of entry into the agency (front & back), customer waiting area, customer service area, and all entrances to the inventory storage area, at all times; each camera must be a digital color camera with zoom capability; equipped with motion detection so that when the office is closed, the cameras will activate with motion; equipped with infrared or motion-activated lighting and repaired or replaced immediately if they become inoperable; the cameras must be operational at all times the office is open; the security camera media and hard drive must be kept secure; it is recommended that recorded video be retained for a rolling 30-day period and is required to be saved for a minimum of 14 days on a rolling calendar period; (2) installation of alarm monitored motion detectors in each room or space, including the records storage room; (3) installation of alarm contacts on all exterior points of entry, including windows that open, and an alarm contact on the door to the records storage room, if applicable; (4) installation of window vibration sensor reporting alarms or alarm monitored motion detectors for windows that could be opened or broken into and entered by an intruder; (5) installation of smoke, fire, and carbon monoxide detection devices; (6) installation of a minimum of one concealed alarm monitored panic/hold-up button under counters between every two computer terminals provided or, if approved by the Registrar, an alternate key fob activated panic/hold-up device; (7) each employee authorized to turn off the alarm system must have a unique security code or biometric code; (8) the security alarm company must be able to provide reports to show by whom and when the alarm was turned on, turned off, and the time and location within the facility of any intrusion; (9) the security alarm company must automatically notify local law enforcement and the deputy registrar to respond if the alarm is set off; (10) all license agencies will provide a crosscut shredder to be made readily available to all customers for the destruction of any customer copies of records that contain personal information about the customer; (11) all records that have exceeded the retention period must be shredded on-site; and (12) provisions for safeguarding (erase/destroy/remove/reformat) all hard drive data (including images) stored on copiers, scanners, and facsimile devices used in the license agency for business purposes when the equipment is disposed, salvaged, sold, recycled, auctioned or otherwise removed from the license agency business. The security system and cameras must be diagnostically tested monthly and verification of operating condition shall be made available to BMV staff for review. The BMV reserves the right to require more or less security measures whenever and wherever needed.

10. **INDEMNIFICATION.** The deputy registrar shall indemnify and hold harmless the Registrar, the Director of Public Safety, the Bureau of Motor Vehicles, the Department of Public Safety, and the State of Ohio upon any and all claims for injuries or damages resulting in any way from the operation of the deputy registrar agency by the deputy registrar or the deputy registrar's agents or employees.

Insurance and hold harmless. The deputy registrar shall maintain during the entire term of his or her contract a policy of business liability, theft, and property damage insurance satisfactory to the Registrar and shall hold the Department of Public Safety, the Director of Public Safety, the Bureau of Motor Vehicles, and the Registrar harmless upon any and all claims for damages or losses arising out of the operation of the deputy registrar agency. The policy shall include coverage of at least \$50,000.00 for BMV property with the Ohio BMV to be added as the second named insured or additional insured; minimum coverage of \$250,000.00 for personal liability; and the Ohio BMV is to be notified immediately of any policy cancellation.

The indemnification and “hold harmless” requirements do not apply to county officials.

11. **BOND REQUIREMENTS.** The deputy registrar shall maintain in full force and effect during the entire term of this contract the bond prescribed by the Registrar pursuant to ORC Section 4503.03(G). The bond shall be on a form prescribed by the Registrar. The amount of the bond shall be \$25,000. Clerks of court and county auditors may be permitted to fulfill the bond requirement by including the BMV onto an existing county bond as an additional insured so long as the county bond sufficiently protects the State, ODPS, and BMV from any acts of dishonesty by the deputy registrar and any or all of the deputy registrar’s employees. The Registrar may adjust the amounts of the bond if there is good cause to do so. However, the amount of the bond shall not be increased during the term of this contract. The bond shall be purchased by the deputy registrar naming the State of Ohio, Department of Public Safety (ODPS), Bureau of Motor Vehicles (BMV), as the bondholder, insured, or additional insured, on the bond itself, in a rider or in an add-on. The bond shall protect the State, ODPS, and BMV from any acts of dishonesty by the deputy registrar and any or all of the deputy registrar’s employees. Any delinquency, default, or cancellation of bond coverage shall be reported immediately by the bonding company to the Bureau of Motor Vehicles, Office of Field Services, P.O. Box 16520, Columbus, Ohio 43216-6520.
12. **COMPUTERS AND BMV-SUPPLIED EQUIPMENT.** The BMV shall supply the deputy registrar with the necessary computers and related equipment, including a camera and printers, necessary to process and produce driver license applications, driver licenses, commercial driver licenses, identification cards, and motor vehicle registrations. The computers and related equipment remain the property of the BMV and shall be surrendered upon the termination of this contract, whether by expiration or at the instance of the Registrar or of the deputy registrar. The deputy registrar shall cooperate in having the equipment returned to the Registrar at the Registrar's request.
13. **INVENTORY.** The BMV also supplies inventories of license plates, validation and county stickers, and many of the forms necessary to transact BMV business. The deputy registrar is responsible to order and maintain adequate, but not excessive, inventories of all items necessary to efficiently serve the needs of the deputy registrar’s customers. The BMV will adopt inventory ordering and delivery schedules and will pay the transportation expenses for all scheduled deliveries. The BMV may charge, and the deputy registrar shall pay, for additional transportation, delivery, or transfer charges caused by the deputy registrar ordering too much or too little inventory.

The deputy registrar is responsible for providing all necessary standard copy/print paper, as well as all standard toner cartridges for BMV provided printers to properly operate the deputy registrar agency. Detailed specifications for deputy registrar-provided paper and toner, along with minimum acceptable inventory levels of each, will be maintained in the Deputy Registrar Manual.

14. **OFFICE HOURS.** The deputy registrar shall maintain the business operating hours as required by ORC Section [4503.03\(D\)](#), the OAC, and as directed and approved by the Registrar. The deputy registrar shall open the agency for other extended hours when the Registrar deems that they are necessary. No agency shall close for lunch. The deputy registrar shall post the agency's hours of operation conspicuously at the front door of the agency. The deputy registrar shall submit to the Registrar in writing any proposed closing, other than a termination of the operation of the agency, at least ten calendar days in advance. Any such closing is subject to prior written consent of the Registrar. In cases of emergency, the Registrar may waive the ten-day notice requirement.
15. **OFFICE MANAGEMENT.** The deputy registrar shall appoint a full-time office manager, who shall be either the deputy registrar himself or herself or a full-time employee with responsibility for management of the agency. The office manager shall be regularly scheduled, and shall work at least thirty-six (36) hours per week during regular business hours. The deputy registrar shall also designate an assistant office manager who shall supervise the agency in the absence of the deputy registrar and the full-time office manager. The deputy registrar shall be on duty at the deputy registrar agency at least twenty (20) hours per week, regularly scheduled, during regular business hours. This twenty-hour requirement does not apply to nonprofit corporations, county auditors, clerks of court, **or deputy registrars operating multiple locations (assessed as received).**
16. **EMERGENCIES.** The deputy registrar shall keep the BMV informed in writing of his or her primary residence address and telephone number where the deputy registrar may be contacted in the event of an emergency. The deputy registrar shall provide the same information with regard to the full-time office manager. The deputy registrar shall promptly notify the BMV of any changes in the above information.
17. **EMPLOYEES.** The parties understand and agree that the deputy registrar is an independent contractor and that any employees engaged by the deputy registrar are employees of the deputy registrar and not employees of the Bureau of Motor Vehicles or the State of Ohio. The deputy registrar agrees that all employees employed in operation of the deputy registrar agency shall be paid at a rate of not less than the state or federal minimum wage rates, whichever is higher.

Background checks. The deputy registrar shall obtain, at the deputy registrar's own expense, background checks of all of the deputy registrar's employees who have not had background checks within the twelve months immediately preceding the start of the contract. No employee or prospective employee shall be authorized to conduct any deputy registrar transaction, unless background reports are on file for that person in compliance with this paragraph.

Background checks (Cont'd.). Criminal background reports shall include, at minimum, checks through the Ohio Bureau of Criminal Investigation (BCI) and Federal Bureau of Investigation (FBI). The Ohio BCI and federal FBI criminal background reports shall be obtained electronically through the WebCheck system operated by the Attorney General of Ohio. If there is reasonable cause to do so, the Registrar or deputy registrar may require any deputy registrar employee to submit conviction reports from federal or local law enforcement agencies or courts. The deputy registrar shall not hire or retain any employee who fails to cooperate in obtaining the required background checks, or who has been convicted within the past ten years of a felony (a crime punishable by death or imprisonment in excess of one year) or any crime involving dishonesty or false statement.

Hiring, compensation and discipline. The deputy registrar shall be responsible for hiring all necessary employees for the agency and shall staff the agency at levels as prescribed by the Registrar. The deputy registrar shall compensate all employees in accordance with the law, the OAC, and his or her proposal. The deputy registrar shall do hiring, promoting, disciplining, and firing on the basis of state and federal laws, rules, and regulations. It is the responsibility of the deputy registrar to conduct employment reference checks of potential employees prior to hire. Persons under 18 years of age are not permitted to work in deputy registrar license agencies **in a position that requires a background check or computer compliance agreement.**

Self-reporting of criminal convictions and driver license suspensions by deputy registrars and deputy registrar employees. A deputy registrar or deputy registrar employee shall report his or her conviction for any criminal offense, felony or misdemeanor (except for minor traffic offense), and any driver license suspension to the BMV Regional Field Offices immediately upon entering a plea of guilty, no contest, or upon entry of conviction or license suspension, whichever occurs first. The Field Services Office shall notify the Registrar, who shall further assess the severity of the reported infraction(s).

Bilingual employees. In locations where the deputy registrar serves a substantial limited English-speaking population, the deputy registrar shall make every reasonable effort to employ bilingual employees who are fluent in English and the predominant language of the limited English-speaking population in that area.

Personnel policy. The deputy registrar shall adopt, maintain, and enforce during the entire term of this contract a comprehensive written personnel policy which shall include, at minimum, provisions for: (1) employee hiring, including provisions for hiring employees experienced in deputy registrar agency employment; (2) equal employment opportunity (EEO) compliance provisions; (3) staff training, including attendance at training offered by the BMV; (4) additional staff training to be offered by the deputy registrar to his or her employees; (5) periodic evaluation of employee performance; (6) a disciplinary plan including a list of grounds for discipline and dismissal, which shall include but is not limited to drug and alcohol use; (7) a plan for progressive discipline; and (8) a specific dress code, including a list of acceptable attire, a list of unacceptable attire and a policy for maintaining the professional appearance of all staff at all times. The personnel plan shall also include any fringe benefits offered to employees. The deputy registrar shall impose discipline in accordance with the personnel policy.

Employee performance. It is the deputy registrar's responsibility that his or her employees perform the duties of their employment and that they be knowledgeable in applicable laws and regulations pertaining to the operation of the deputy registrar agency, and that they perform their duties in a competent and efficient manner. The deputy registrar shall be responsible for the acts or failure to act of his or her employees.

Staffing levels. During periods of high volume, the deputy registrar shall have all terminals within the agency fully staffed. The deputy registrar shall maintain staffing at the rate prescribed by the Registrar based upon the number of transactions. Recommended weekly staff hours are set forth in RFP Section 1.5, Agency Specifications. The deputy registrar shall adopt record keeping procedures sufficient to ensure BMV representatives that staffing requirements are fully met. The deputy registrar shall adopt procedures to provide direct customer assistance to ensure that customers standing in line have proper documentation for their intended transactions. The deputy registrar shall have a notary public on duty at all times during the business hours of the agency.

Roster of employees. The deputy registrar shall provide the BMV, on a continuing basis, with a roster containing the names, addresses, dates of birth, home telephone numbers and working hours of all the deputy registrar's employees.

Training. The deputy registrar and the employees of the deputy registrar shall attend all necessary training sessions as prescribed by the Registrar and shall pay all travel and meal expenses incurred. The cost of all BMV-conducted training (tuition) shall be borne by the BMV. All deputy registrars and license agency employees are required to receive comprehensive training in license agency business operational policies, procedures, and practices prior to independently performing any type of license agency transactions. Comprehensive training shall include, but not be limited to; new employee training, mandatory BMV fraudulent document training, new legislated or BMV-initiated process and procedures training, and any other training determined by the BMV to be necessary for operating a deputy registrar license agency business.

Equal opportunity. In carrying out this contract, the deputy registrar shall not discriminate against any employee or applicant for employment on the basis of race, color, national origin, religion, sex, disability, age, sexual orientation, or any other basis which would be illegal under state or federal law, regulation, or rule. The deputy registrar shall ensure that applicants are hired, and that employees are treated during employment, without regard to the bases listed above. Such action shall include but not be limited to the following: employment, advertising, layoff or termination, rates of pay or other forms of compensation, and selection for training.

Notice of equal opportunity. The deputy registrar shall post in conspicuous places available to all employees and applicants for employment notices setting forth the provisions of this nondiscrimination clause. The deputy registrar shall, in all solicitations or advertisements for employees placed by or on his or her behalf, state that all qualified applicants will receive consideration for employment without regard to race, color, national origin, religion, sex, disability, age, or sexual orientation. Failure to hire qualified minorities in accord with Federal Equal Employment Opportunity (EEO) laws shall be grounds to terminate this contract.

Equal opportunity in services. The deputy registrar shall offer services to members of the public without regard to race, religion, color, national origin, sex, disability, age, or sexual orientation and shall not discriminate in the provision of services. No person in the United States shall, on the grounds of race, color, national origin, sex, age, disability, low-income, or LEP be excluded from participation in, be denied the benefits of, or be otherwise subjected to discrimination under any program or activity for which the Recipient receives Federal financial assistance from DOT, including the FMCSA.

The Ohio Department of Public Safety, in accordance with the provisions of Title VI of the Civil Rights Act of 1964 (78 Stat. 252, 42 U.S.C. §§ 2000d to 2000d-4) and the Regulations. Hereby notifies all bidders that it will affirmatively ensure that any contract entered into pursuant to this advertisement, all contractors will be afforded full opportunity to submit bids in response to this invitation and will not be discriminated against on the grounds of the owner's race, color, national origin, sex, age, disability, income level, or LEP in consideration for an award.

During the performance of this contract, the contractor, for itself, its assignees, and successors in interest (hereinafter referred to as the "contractor") agrees as follows:

Compliance with regulations. The contractor (hereinafter includes consultants) will comply with the Acts and the Regulations relative to Nondiscrimination in Federally-assisted programs of the U.S. Department of Transportation, Federal Motor Carrier Safety Administration (FMCSA), as they may be amended from time to time, which are herein incorporated by reference and made a part of this contract.

Nondiscrimination. The contractor, with regard to the work performed by it during the contract, will not discriminate on the grounds of race, color, national origin, sex, age, disability, income-level, or LEP in the selection and retention of subcontractors, including procurements of materials and leases of equipment. The contractor will not participate directly or indirectly in the discrimination prohibited by the Acts and the Regulations as set forth in Appendix E, including employment practices when the contract covers any activity, project, or program set forth in Appendix B of 49 C.F.R. part 21.

Solicitations for subcontracts, including procurements of materials and equipment. In all solicitations, either by competitive bidding, or negotiation made by the contractor for work to be performed under a subcontract, including procurements of materials, or leases of equipment, each potential subcontractor or supplier will be notified by the contractor of the contractor's obligations under this contract and the Acts and the Regulations relative to Non-discrimination on the grounds of race, color, national origin, sex, age, disability, income-level, or LEP.

Information and reports. The contractor will provide all information and reports required by the Acts, the Regulations and directives issued pursuant thereto and will permit access to its books, records, accounts, other sources of information, and its facilities as may be determined by the Recipient or the FMCSA to be pertinent to ascertain compliance with such Acts, Regulations, and instructions. Where any information required of a contractor is in the exclusive possession of another who fails or refuses to furnish the information, the contractor will so certify to the Recipient or the FMCSA, as appropriate, and will set forth what efforts it has made to obtain the information.

Sanctions for noncompliance. In the event of a contractor's noncompliance with the non-discrimination provisions of this contract, the Recipient will impose such contract sanctions as it or the FMCSA may determine to be appropriate, including, but not limited to: withholding payments to the contractor under the contract until the contractor complies; and/or cancelling, terminating, or suspending a contract, in whole or in part.

Incorporation of provisions. The contractor will include the provisions of paragraphs one through six in every subcontract, including procurements of materials and leases of equipment, unless exempt by the Acts, the Regulations and directives issued pursuant thereto. The contractor will take action with respect to any subcontract or procurement as the Recipient or the FMCSA may direct as a means of enforcing such provisions including sanctions for noncompliance. Provided, that if the contractor becomes involved in, or is threatened with litigation by a subcontractor, or supplier because of such direction, the contractor may request the Recipient to enter into any litigation to protect the interests of the Recipient. In addition, the contractor may request the United States to enter into the litigation to protect the interests of the United States.

During the performance of this contract, the contractor, for itself, its assignees, and successors in interest (hereinafter referred to as the "contractor") agrees to comply with the following non-discrimination statutes and authorities; including but not limited to:

Title VI of the Civil Rights Act of 1964 (78 Stat. 252, 42 U.S.C. § 2000d *et seq.*), (prohibits discrimination on the basis of race, color, national origin), as implemented by 49 C.F.R. § 21.1 *et seq.* and 49 C.F.R. part 303;

The Uniform Relocation Assistance and Real Property Acquisition Policies Act of 1970, (42 U.S.C. § 4601) (prohibits unfair treatment of persons displaced or whose property has been acquired because of Federal or Federal-aid programs and projects);

Federal-Aid Highway Act of 1973 (23 U.S.C. § 324 *et seq.*) (prohibits discrimination on the basis of sex);

Section 504 of the Rehabilitation Act of 1973, as amended (29 U.S.C. § 794 *et seq.*) (prohibits discrimination on the basis of disability); and 49 C.F.R. part 27;

The Age Discrimination Act of 1975, as amended (42 U.S.C. § 6101 *et seq.*) (prohibits discrimination on the basis of age);

Airport and Airway Improvement Act of 1982 (Pub. L. 97-248 (1982)), as amended (prohibits discrimination based on race, creed, color, national origin, or sex);

The Civil Rights Restoration Act of 1987 (102 Stat. 28) ("*...which restore[d] the broad scope of coverage and to clarify the application of title IX of the Education Amendments of 1972, section 504 of the Rehabilitation Act of 1973, the Age Discrimination Act of 1975, and title VI of the Civil Rights Act of 1964.*");

Titles II and III of the Americans with Disabilities Act, which prohibit discrimination on the basis of disability in the operation of public entities, public and private transportation systems, places of public accommodation, and certain testing entities (42 U.S.C. §§ 12131 -- 12189), as implemented by Department of Justice regulations at 28 C.F.R. parts 35 and 36, and Department of Transportation regulations at 49 C.F.R. parts 37 and 38;

The Federal Aviation Administration's Non-discrimination statute (49 U.S.C. § 47123) (prohibits discrimination on the basis of race, color, national origin, and sex);

Executive Order 12898, Federal Actions to Address Environmental Justice in Minority Populations and Low-Income Populations, which ensures non-discrimination against minority populations by discouraging programs, policies, and activities with disproportionately high and adverse human health or environmental effects on minority and low-income populations;

Executive Order 13166, Improving Access to Services for Persons with Limited English Proficiency, and resulting agency guidance, national origin discrimination includes discrimination because of limited English proficiency (LEP). To ensure compliance with Title VI, you must take reasonable steps to ensure that LEP persons have meaningful access to your programs (70 Fed. Reg. at 74087 to 74100);

Title IX of the Education Amendments of 1972, as amended, which prohibits you from discriminating because of sex in education programs or activities (20 U.S.C. § 1681 *et seq.*).

Avoidance of sexual harassment. The deputy registrar shall adopt and enforce a policy which prohibits sexual harassment in any form or manner. The deputy registrar immediately shall notify the Registrar in writing whenever there is any allegation of sexual harassment, whether or not there is any foundation for the allegation.

Withholding taxes and premiums. The deputy registrar accepts full responsibility for the payment of all unemployment compensation premiums, all workers' compensation premiums, social security contributions and any and all taxes for which he or she is legally responsible. The deputy registrar shall comply with all applicable federal, state, and local laws regulating the withholding of income taxes or other taxes from the employees' paychecks.

Federal Insurance Contributions Act (FICA) tax. FICA is a tax imposed on both employers and employees to fund Social Security and Medicare. Employees of the State of Ohio and its political subdivisions, including county auditors, clerks of court, and their employees are exempt from paying the Social Security portion of FICA taxes because they are covered by an alternative retirement and pension plan under the Ohio Public Employees Retirement System (OPERS). Individual deputy registrars and nonprofit corporation deputy registrars are independent contractors and are not employees of Ohio or its political subdivisions. Therefore, individual deputy registrars, nonprofit corporation deputy registrars, and their respective employees are not eligible to be covered by OPERS, and are required to withhold and pay all FICA taxes.

Workers' compensation. The deputy registrar shall apply for a workers' compensation risk number in the deputy registrar's name, shall pay all premiums, claims, and expenses incurred for the deputy registrar's employees and shall indemnify and hold the BMV harmless on any liability for the same.

Credit disclosure. The deputy registrar may require license agency employees to provide disclosure of credit information only within strict accordance with the provisions contained in The Fair Credit Reporting Act.

18. **BANKING REQUIREMENTS.** Pursuant to R.C. 4503.10, the Registrar, subject to the approval of the Director, may designate a local bank or depository for deposit of all State funds. Where the Registrar has designated a local bank or depository, the deputy registrar shall deposit all state monies collected by the deputy registrar into that bank or depository to the credit of the "State of Ohio, Bureau of Motor Vehicles" not more than one business day after their collection. The deputy registrar shall comply with the provisions of the ORC, the OAC, this contract, the Deputy Registrar Manual, and any directives from the Registrar in the collection, deposit, and reporting of, and accounting for, all State monies.

The deputy registrar shall, on a daily basis: have a bank teller or official verify each deposit form; transmit sales data and deposit information by computer terminal to the BMV; and prepare and submit daily deposit forms, together with all documentation prescribed by the Registrar. If the Registrar does not designate a local bank or depository, the deputy registrar shall establish an account in a bank or depository located in the State of Ohio. The account shall meet all requirements prescribed by the Registrar. If the account does not meet those requirements, the Registrar may require the deputy registrar to establish a new account in an approved financial institution which meets all requirements prescribed by the Registrar. The deputy registrar shall notify the Registrar in writing at least thirty days prior to changing the depository bank for the State demand account. Such change shall be made by the deputy registrar only with the advance written consent of the Registrar.

Prohibition against commingling. The monies collected by the deputy registrar on behalf of the State shall be deposited into the State account. The deputy registrar shall maintain a separate account for all other funds and shall not commingle State funds with funds from any other account.

Acceptance of checks. The deputy registrar shall accept personal and business checks only if made payable to Ohio Treasurer of State in payment for motor vehicle registrations, driver licenses, commercial driver licenses and identification cards, and in payment of the statutory fees associated with those transactions, in a manner prescribed by the Registrar. If a check is made payable to Ohio Treasurer of State, and is received in strict compliance with the procedures prescribed by the Registrar, the BMV shall accept liability for the check. In such case, the deputy registrar shall not accept payment for any check returned for insufficient funds, but shall refer the matter to the BMV for collection. If the check is not received in strict compliance with the regulations prescribed by the Registrar, the deputy registrar shall be liable for any check returned for insufficient funds or any other dishonor.

Effect of Federal Check Clearing for the 21st Century Act. The parties acknowledge that Congress has passed a federal law commonly known as the Check 21 Act. To comply with this act, banks may start requiring that all checks be imaged and electronically deposited to the account instead of depositing the paper checks. This would require the deputy registrar to scan all checks received each business day and submit an electronic batch file to the bank, and secure the original paper checks on site for a minimum of fourteen business days before they can be destroyed. The BMV and the deputy registrars may be required to comply with the mandated changes. It is unknown what all of the requirements on the BMV or the deputy registrar would be if banks require that checks be imaged and transmitted electronically. The BMV and the deputy registrar agree to cooperate to accomplish any changes in a mutually beneficial way to the extent it is practical to do so.

19. **CREDIT AND DEBIT CARDS, ETC.** Pursuant to R.C. 4503.102(H)(1)(2)(3), and effective July 1, 2016, the BMV will implement the acceptance of financial transaction devices (credit cards, debit cards, charge cards, prepaid or stored value cards, etc.) in payment of state taxes and fees and deputy fees directly related to official BMV transactions only. The acceptance of financial transaction devices for payment of other services will not be available at time of implementation but may be available in the future. The implementation of financial transaction devices does not prohibit the use of automated transaction machines (ATMs) within the deputy registrar agencies.
20. **TELEPHONE ACCESSIBILITY.** The deputy registrar shall maintain sufficient business telephone lines and adequate personnel to meet the demands of the agency. The deputy registrar must establish and maintain a listing in the local business white pages in accordance with instructions prescribed by the Registrar. The deputy registrar shall notify the Registrar in writing at least thirty days prior to any proposed change in the agency's phone number. Such change may be made only with the advance written consent of the Registrar.

The deputy registrar shall make his or her office telephone number available to the BMV or to any successor deputy registrar, if requested by the BMV, and also cooperate in having telephone calls forwarded through the telephone company if the successor deputy registrar has a different telephone number. The deputy registrar agrees to pay reasonable damages to the BMV and any successor deputy registrar for failure to comply with this paragraph.

21. **RECORD KEEPING.** The deputy registrar shall maintain records and make them available to BMV representatives for inspection sufficient to show that the deputy registrar has complied with the requirements of this contract.

Records retention. Pursuant to R.C. 4501.021, the Registrar shall determine the methods for obtaining, collecting, recording, and maintaining the records of the deputy registrars that pertain to driver's or commercial driver's licenses, identification cards, and vehicle registrations, including photographic or digitalized images, and electronic or digitalized signatures. The registrar may choose methods including paper, film, digital or other electronic media, or any other media that reasonably allows for recording, maintaining, and retrieving the records in a reliable manner, and the deputy registrar shall conform to those methods. Each deputy registrar shall retain copies of all records and transactions performed for the BMV in accordance with methods and retention periods prescribed by the Registrar.

22. **MINIMUM SITE CRITERIA.** This contract is contingent upon the deputy registrar's maintaining in force during the entire contract period a lease or sublease that extends, by its terms, to the end of the contract period or ownership of the premises, and upon the deputy registrar's remaining at the site agreed to at the time of the contract award, subject to the advance written consent of the Registrar allowing the deputy registrar to move to a new site. The deputy registrar shall maintain a clean, orderly, and well-lit place of business. The deputy registrar shall provide adequate parking for customers, including disability parking, as prescribed by the Registrar. The deputy registrar shall provide accessibility to individuals with disabilities, an adequate waiting area, adequate air conditioning, heating, ventilation, lighting and restroom facilities for employees. The entire deputy registrar premises shall be smoke-free. The site shall be in compliance with the (federal) Americans with Disabilities Act, Public Law 101-336, 42 U.S.C. Section 12101, et seq., as amended.

23. **LEASE FILING AND LEASE CONTINUATION AGREEMENT.** The deputy registrar shall keep on file with the BMV at all times a copy of the current lease for the deputy registrar agency site.

In addition, a deputy registrar operating at a Deputy Provided Site is strongly encouraged, if awarded a contract, to obtain a fully executed lease continuity agreement (LCA) signed by the deputy registrar, the property owner (lessor), and the Registrar. The purpose of the LCA is to give the BMV an opportunity to continue the operation of a deputy registrar agency at the same location in the unlikely event that the deputy registrar does not continue the operation of the agency through the entire term of the deputy registrar contract.

24. **BUSINESS ENVIRONMENT.** The deputy registrar shall provide a clean, healthy business environment and a friendly and efficient driver licensing and vehicle registration service to all patrons, as well as information on optional mail-in, telephone and online vehicle registration, and all highway and public safety promotions.

25. **FACILITY STANDARDS.** The deputy registrar shall maintain, in accordance with the requirements prescribed by the Registrar, climate control, adequate restroom facilities, a security plan for the safety of the agency's employees and patrons, agency accessibility, and a facility maintenance plan. The deputy registrar shall comply with all applicable Ohio Building Code requirements and the Americans with Disabilities Act (ADA) when constructing or remodeling the deputy registrar agency.

Facility maintenance. The deputy registrar shall adopt an acceptable facility maintenance plan and shall be responsible for assuring that the interior and exterior of the deputy registrar agency premises are maintained in a clean, safe, and attractive condition at all times. The facility maintenance plan shall, at minimum, provide that any carpeting and/or flooring be professionally cleaned as needed and no less than once per year and that the walls be maintained at all times and be repainted at least once during the term of the contract. Facility floors, walls, and ceilings must be maintained to be free of stains or debris. Facility windows and doors must be maintained to be free of fingerprints, smudges, dirt, and debris.

Counters. The deputy registrar is responsible for providing counters to accommodate the BMV supplied equipment to serve customers in a convenient manner, and to accommodate the efficiency and comfort of the deputy registrar's employees.

Office furniture, equipment and supplies. The deputy registrar is responsible for providing all office equipment and supplies except the computers and the BMV-supplied equipment and inventory. The deputy registrar is responsible for providing all office furniture for both employees and customers (desks, chairs, tables, etc.), office equipment (typewriter, calculators, file cabinets, trash receptacles, shelving, etc.), a copy machine, a document cross-cut shredder, and a fax machine (or a machine capable of both), a safe or secure locking cabinet, and office supplies necessary to operate the deputy registrar agency. The Registrar may adopt, and require the deputy registrar to maintain, standards for the furnishing of the agency sufficient to assure the comfort and safety of customers and employees.

Special provisions for certain BMV Controlled Sites. For certain BMV Controlled Sites, the BMV may make arrangements for the installation of the alarm system, the construction or modification of counters, the installation or modification of signs, any other mandatory equipment, and any or all equipment or furnishings required to ensure the comfort of customers and employees. The deputy registrar shall either pay for any such improvements or shall reimburse the BMV for any such improvements at the BMV's actual costs, usually on an amortized basis, and shall be responsible for maintaining those improvements during the term of the contract.

Signs. The deputy registrar shall ensure that the agency is well marked, with adequate signs to enable potential patrons to locate the agency conveniently. The signs identifying the deputy registrar agency shall be sufficient to identify the agency, shall comply with all applicable zoning requirements, and shall include at least one outside sign. **Beginning with contracts awarded on or after January 1, 2020, each deputy registrar shall, within six months of contract award, update all agency signage to reflect the current BMV logo (brand).** Sign specifications and provisions are contained within the Deputy Registrar Manual. The Registrar may change these specifications from time to time, and the deputy registrar shall comply with any changes in specifications.

26. **EVALUATION.** The deputy registrar shall make available for review by the Director, the Registrar, or the Auditor of State or their designated representatives the records and files of all transactions pertaining to BMV business. This review may be performed at the deputy registrar's agency or at any other place to be determined by the Director or Registrar.

Correction and deficiencies. The Registrar shall appoint persons to evaluate the operation of the deputy registrar agency on a continuing basis to assure compliance. The deputy registrar agrees to correct any deficiencies at the earliest reasonable time. The deputy registrar understands and agrees that, depending on the severity of any problems that may be found to exist, this contract or eligibility for any further contract to operate a deputy registrar agency may be dependent upon the deputy registrar complying with his or her duties under this Contract, the ORC, the OAC, the RFP, the Deputy Registrar Manual, communications from the BMV, and any other matter prescribed by the Registrar.

27. **LIQUIDATED DAMAGES.** Since any actual damages that may be incurred by the Department of Public Safety and the BMV as a result of the deputy registrar's failure of performance or default may be difficult to ascertain, the Registrar may require the payment of liquidated damages by the deputy registrar. The payment of liquidated damages may be required for any material failure of performance, or default, in the amount of fifty dollars per day for each terminal assigned to the agency. "Material failure of performance," or "default," as used in this paragraph, includes: (1) an unsatisfactory score on any evaluation performed by a designee of the Registrar; (2) a failure of performance of the deputy registrar's obligations described in the applicable paragraphs of the OAC; (3) any ground that would justify termination of this contract for cause; or (4) any ground that would justify disqualification of a proposer to be awarded a contract. The BMV shall provide written notice of default to the deputy registrar. Such notice shall specify a reasonable time, not less than seventy-two hours from receipt of written notice, to cure the default. Service of written notice is complete upon its delivery to the deputy registrar personally or to the agency. If it is delivered to the agency, the time to cure begins to run immediately, provided that the agency is open or is scheduled to be open; otherwise, it begins to run when the agency next opens or is next scheduled to open. If the default is not cured by the deadline, the deputy registrar shall immediately begin to pay liquidated damages each day, and shall continue to pay each day until the day that the deputy registrar and the Registrar agree that the default has been cured. The Registrar may grant an extension of the deadline to cure. The deputy registrar agrees that liquidated damages are not required as a penalty, but as compensation to the BMV. The BMV's exercise of its rights under this paragraph is in addition to all other rights and remedies. Neither the Registrar's use or waiver of the BMV's rights under this paragraph shall constitute a waiver by the Registrar of any other term of this contract.
28. **CLOSURE OF AGENCY UPON DEATH OR DISABILITY OF DEPUTY REGISTRAR.** The deputy registrar shall appoint an employee whose duty it shall be to notify the Registrar within twenty-four hours in case of the death, disability, incarceration, or unavailability of the deputy registrar. The operation of the deputy registrar agency shall cease upon the death, disability, incarceration exceeding seventy-two hours, or unavailability of the deputy registrar, and shall not reopen until such time as the Registrar appoints an interim deputy registrar or a new deputy registrar.

29. **TERMINATION BY DEPUTY REGISTRAR.** The deputy registrar may terminate this contract only by giving ninety days' written notice to the Registrar. Such a notice shall not operate to make the deputy registrar eligible to enter into any other deputy registrar contract whose term begins before the term of this contract is scheduled to end. The deputy registrar agrees that he or she will not cease to conduct his or her business until adequate arrangements have been made by the Registrar and the Registrar agrees to the arrangements in writing.
30. **TERMINATION BY REGISTRAR.** The Registrar shall, with the approval of the Director, terminate this contract and immediately remove the deputy registrar if the deputy registrar violates any provision of the ORC related to his or her duties as a deputy registrar, any rule adopted by the Registrar, or any term of this contract. The contract may also be terminated by act of the Ohio General Assembly.
31. **REMOVAL OF DEPUTY REGISTRAR.** The Registrar may, with the approval of the Director, remove a deputy who, in the opinion of the Registrar, has engaged in any conduct that is either unbecoming of one representing the State or is inconsistent with the efficient operation of the deputy registrar agency.
32. **GOOD FAITH.** The deputy registrar agrees to act in good faith in the performance of all obligations under this contract.
33. **START OF BUSINESS.** The deputy registrar shall have all office equipment, supplies, and inventory in place, and shall have all employees properly trained, and shall have the deputy agency open for business no later than 8:00 a.m. on the first day of the contract period (Sundays excepted).
34. **AMENDMENT.** This contract may be amended only by a written instrument executed by both parties with the same formality as this contract.
35. **GOVERNING LAW; SEVERABILITY.** This contract shall be governed by and construed in accordance with the laws of the State of Ohio. If any provision of this contract is declared unconstitutional or legally deficient in any other respect, all remaining provisions of this contract shall be severable and shall remain in full force and effect.
36. **NO ASSIGNMENT.** The deputy registrar shall not assign this contract at any time, in whole or in part, nor any of the deputy registrar's responsibilities, without the advance written consent of the Registrar. Any such attempt to assign this contract shall be void.
37. **EFFECT OF FEDERAL REAL ID ACT.** The parties acknowledge that Congress has passed a federal law commonly known as the Real ID Act. If Ohio chooses to comply with the Real ID Act in whole, or in part, it will affect significantly the way the Registrar and deputy registrars process and issue driver licenses, commercial driver licenses (CDLs), and state identification (ID) cards. Changes may include additional security requirements by the BMV. The BMV and the deputy registrar agree to cooperate to accomplish any changes in a mutually beneficial manner to the extent it is practical to do so.

38. **ANIMALS ON PREMISES.** Neither the deputy registrar nor any deputy registrar employee shall keep a pet or animal of any kind on the agency premises. This prohibition does not apply to “assistance dogs,” “guide dogs,” “hearing dogs,” “service dogs,” dogs assisting law enforcement, other recognized “service animals,” or aquatic life contained in a well-maintained aquarium.

Customers with recognized “Assistance Animals” are permitted to enter deputy registrar agencies to conduct business.

Service animals are defined as animals that are individually trained to do work or perform tasks for people with disabilities. Examples of such work or tasks include guiding people who are blind, alerting people who are deaf, pulling a wheelchair, alerting and protecting a person who is having a seizure, reminding a person with mental illness to take prescribed medications, calming a person with Post Traumatic Stress Disorder (PTSD) during an anxiety attack, or performing other duties. Service animals are working animals, not pets. The work or task an animal has been trained to provide must be directly related to the person’s disability.

39. **NO GIFTS OR TIPS TO BE ACCEPTED.** To avoid the appearance of impropriety, the deputy registrars, their employees (full or part-time), and any independent contractors working for them who provide service(s) to any BMV customer shall refrain from, and are hereby prohibited from, accepting any money tips, gifts, services, or anything of value for themselves, or any of their family members or friends from their deputy registrar customers.

Anything of value shall include, but not be limited to: gift cards and other cash equivalents, money, bonds, money tips, checks, gifts of goods or services, special privileges, tickets, coupons, samples, exchanging of anything of value, demo products, services or the like.

41. **VENDING SERVICE.** A deputy registrar may operate or contract for the operation of a vending machine at a deputy registrar location if products of the vending machine are consistent with the functions of a deputy registrar. Deputy registrar agencies may operate, or contract to operate, a soft drink or a candy/snack vending machine in the customer service area. It is the responsibility of each deputy registrar to maintain the cleanliness of the vending machine area. A deputy registrar that elects to operate, or contracts to operate, a vending machine shall be financially responsible for any damages to BMV equipment, or supplies that are damaged as a result of the vending machine or any products sold from the vending machine. All contracts and proceeds regarding the operation of the vending machines are the sole responsibility of the deputy registrar.

42. **COLLECTION OF REINSTATEMENT FEES.** At least one deputy registrar in each county shall be afforded the opportunity to be equipped to accept payment for driver license reinstatement fees. The deputy registrar shall collect a service fee of ten dollars for compensation for the services performed. The deputy registrar shall retain eight dollars of the service fee and shall transmit the reinstatement fee, plus two dollars of the service fee, to the registrar for the cost of equipment and/or services provided necessary in connection with accepting reinstatement fees.

43. **MINORITY BUSINESS ENTERPRISE CERTIFIED.** The Ohio Department of Administrative Services grants Minority Business Enterprise (MBE) certification for a period not to exceed two years, at which time recertification may be required. All MBE certified Deputy Registrars are encouraged to maintain a valid MBE certification status throughout the entire term of the deputy registrar contract.

44. **ENTIRE CONTRACT.** This contract incorporates by reference the ORC, the OAC, the RFP, the deputy registrar's proposal, the Deputy Registrar Manual, directives from the Registrar via the BMV, as well as any other matter prescribed by the Registrar or the BMV. This contract, along with those items mentioned directly above, constitute the entire contract between the parties. In case of any inconsistency among the above-mentioned items, the inconsistency shall be resolved by giving preference to these items in the following order: the ORC, the OAC, this Contract, the RFP, the Deputy Registrar Manual, directives from the Registrar via the BMV, any other matter prescribed by the Registrar or the BMV, and the deputy registrar's proposal. **Upon signing and submission of a proposal, the proposer shall adhere to the rules set forth by the entire contract.** No officer, employee, or agent of the parties is authorized to make any representation, warranty, or promise not contained in one of the above-mentioned documents.

NOTE: KEEP A PRINTED OR ELECTRONIC COPY OF THIS ENTIRE RFP DOCUMENT. IF YOU ARE AWARDED A CONTRACT, THE RFP DEFINES THE TERMS OF YOUR RIGHTS AUTHORITY DUTIES AND OBLIGATIONS.

End of 2026 Deputy Registrar Terms and Conditions